



Sri Ramakrishna Mission Vidyalaya  
**INDUSTRIAL TRAINING CENTRE**

Sri Ramakrishna Vidyalaya Post - Coimbatore - 641 020 - Tamilnadu

**PLUMBER**



# Table of Contents

<b>Chapter 1: Introduction to Plumbing</b>	<b>1</b>
<b>Chapter 2: Plumbing Terminologies</b>	<b>5</b>
<b>Chapter 3: Basic Planning for Plumbing</b>	<b>23</b>
3.1 Location of Washrooms, Kitchens and Utility areas	
3.2 Sizes of Washrooms, Kitchens and Utility areas	
3.3 Plumbing Fixtures and Fittings	
3.4 Safety Features	
<b>Chapter 4: Water Supply</b>	<b>37</b>
4.1 Estimation of Daily Water Requirements	
4.2 Water Sources	
4.3 Quality of Water and Treatment	
4.4 Water Storage	
4.5 Water Distribution	
4.6 Hot Water Generation and Distribution	
4.7 Safety Measures in Water Distribution	
<b>Chapter 5: Soil and Waste Drainage</b>	<b>51</b>
5.1 General	
5.2 Types of installations	
5.3 Sizing of Pipes for Drainage	
5.4 Vents	
5.5 Inspection Chambers and Manholes	
5.6 Gravity Drains and Pumped Sewers	
5.7 Sewage Treatment Systems	
<b>Chapter 6: Rainwater Drainage and Harvesting</b>	<b>63</b>
6.1 Rainfall Intensity	
6.2 Drainage Systems	
6.3 Siphonic Rainwater System	
6.4 Collection and Storage	
6.5 Recharge and Disposal Systems	
<b>Chapter 7: Retrofitting of Plumbing Systems</b>	<b>69</b>
7.1 General	
7.2 Sanitary Fixtures and Appliances	

7.3 Augmentation of Water Storage	
7.4 Improvements of Piping Systems	
<b>Chapter 8: Materials/Equipment</b>	<b>73</b>
8.1 Sanitary Fixtures and Fittings	
8.2 Water Supply	
8.3 Drainage	
8.4 Pumping Equipment	
<b>Chapter 9: Washrooms for Differently Abled</b>	<b>75</b>
<b>Chapter 10: Water Conservation</b>	<b>81</b>
10.1 General	
10.2 Water Conservation Measures	
<b>Chapter 11: Operation and Maintenance</b>	<b>83</b>
<b>Chapter 12: Records</b>	<b>85</b>
<i>Suggested Additional Reading</i>	<i>87</i>
<i>Acknowledgements</i>	<i>89</i>

# Introduction to Plumbing

The service that provides safe potable water at adequate pressures and quantities at desired locations within living spaces and carrying away waste matter in a hygienic manner, can broadly be termed as the practical meaning of the word 'Plumbing' in the context of a developing nation like India. Whilst practices in various countries might vary, the fundamentals generally remain the same.

A typical plumbing system shall include identification of appropriate source(s) of water, storage, treatment, conveyance and distribution of the same to the required locations. This process may involve usage of several products and appliances such as storage vessels, treatment units, pumping equipment, piping, valves, accessories, etc. An appropriate installation shall ensure user comforts at the various plumbing fixtures such as water closets, wash basins, showers, sinks, faucets, etc.

An equally important aspect of a plumbing system is safe and hygienic means of conveyance and disposal of used water and human waste. This will also involve several products and accessories such as pipes, traps, inspection chambers, treatment systems, etc.

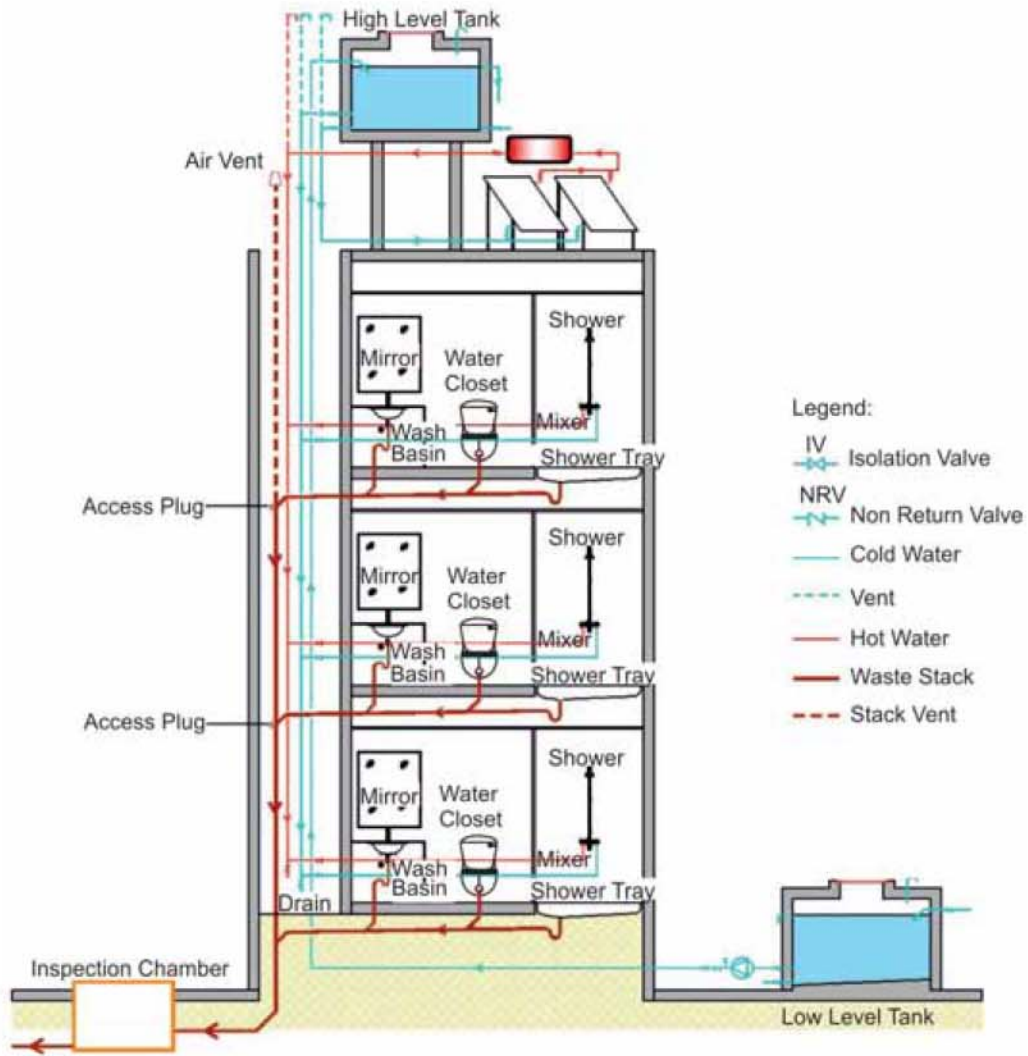

Figure 1.1: Typical Plumbing System (Gravity Water Distribution)

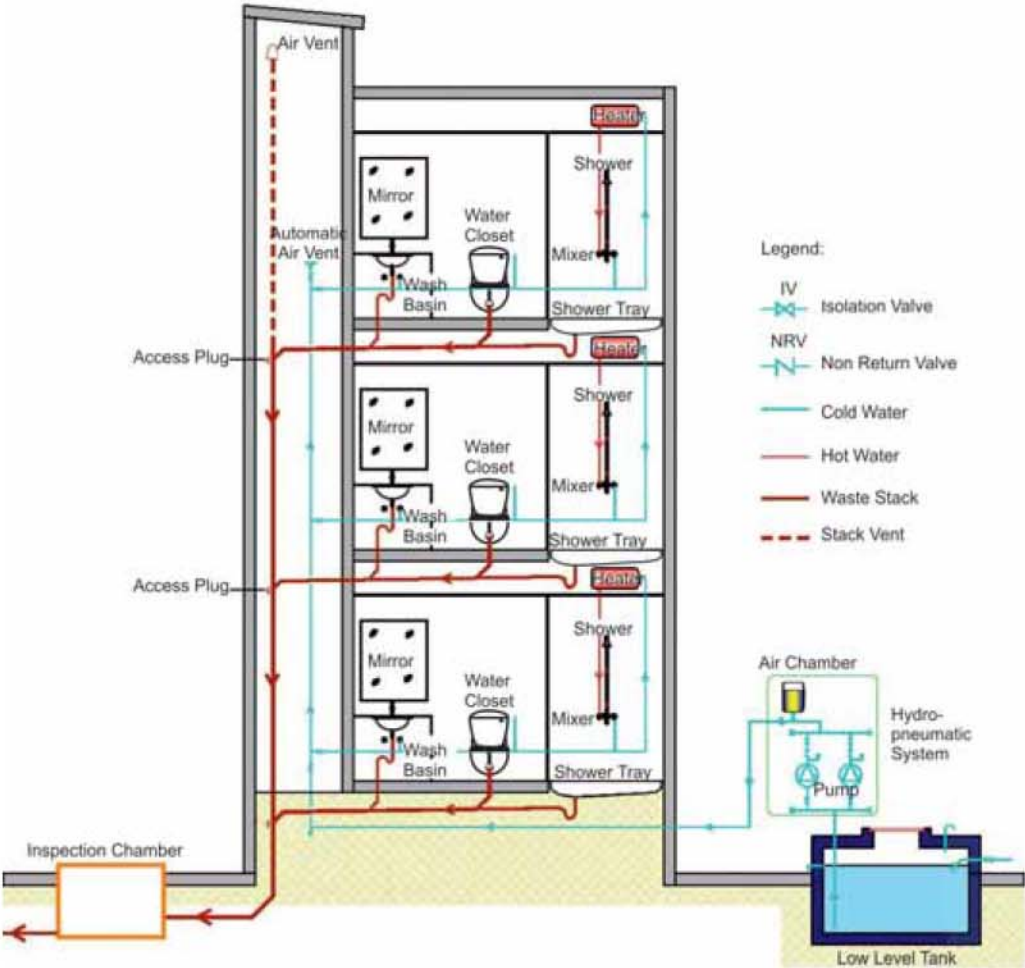

Figure 1.2: Typical Plumbing System (Pressurized Water Distribution)



# Plumbing Terminologies

## 2.1 Airgap

Airgaps are provided in water supply and drainage systems as a means to prevent cross contamination, e.g. when a waste pipe from a water cooler, ice cube machine or similar appliance handling food or potable water is discharged to a floor drain, an airgap (an unobstructed vertical distance) ensures contamination from the drain

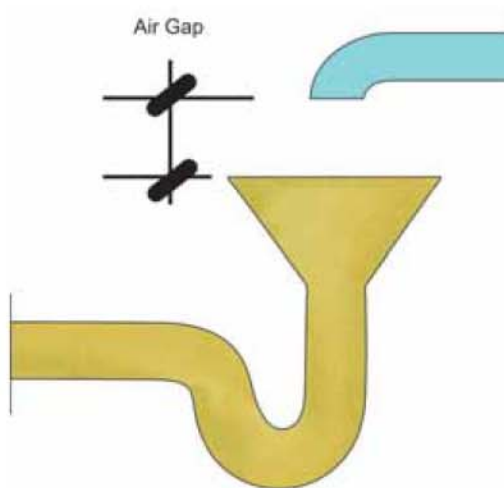

Figure 2.1a: Airgap-Drainage

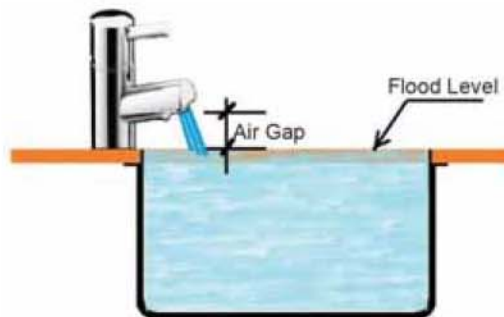

Figure 2.1b: Airgap-Water Supply



does not occur back into the appliance through a contact with the waste pipe. Likewise, an airgap should be maintained when the condensate drain from an air conditioning unit is connected to a drain to prevent bacterial contamination of the air conditioning system.

Similarly, a faucet installed over a sink should have an airgap (min. 25 mm) from the outlet of the faucet to the overflow level of the sink.

## 2.2 Backflow

The terminology is commonly used to describe the effects of incorrect connections to potable water distribution system. An example can be, cross connection between two different qualities of water through piping in a building where water of a lesser quality is used for flushing purposes. Connection of a pipe carrying such flushing water to a pipe carrying drinking water can be hazardous.

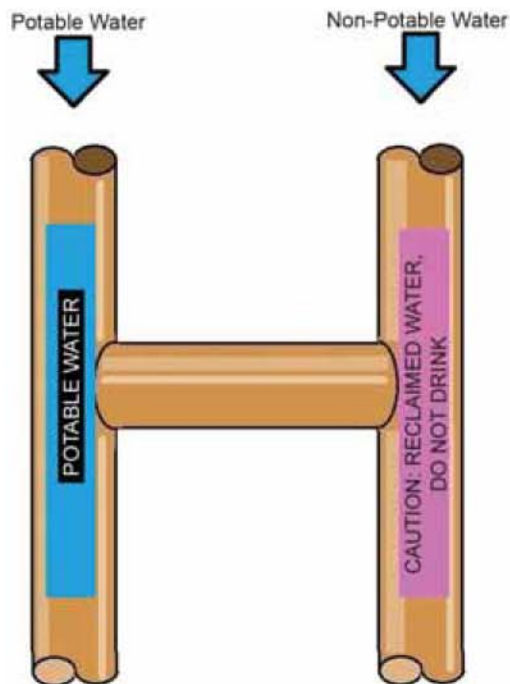

*Figure 2.2: Backflow (with Cross Connection)*

## 2.3 Back-Siphonage

Back-siphonage can occur when a water main passes through a puddle of contaminated water. Often negative pressures occur within the water main when the water supplies are interrupted resulting in the contaminated water from the surroundings being sucked into the water main through improper pipe joints/damaged pipes. Another example is when the open end of a garden hose is left loose that may suck in polluted water containing fertilizers, pesticides, etc. Back-siphonages as described above can cause serious health hazard due to contamination of domestic water systems.

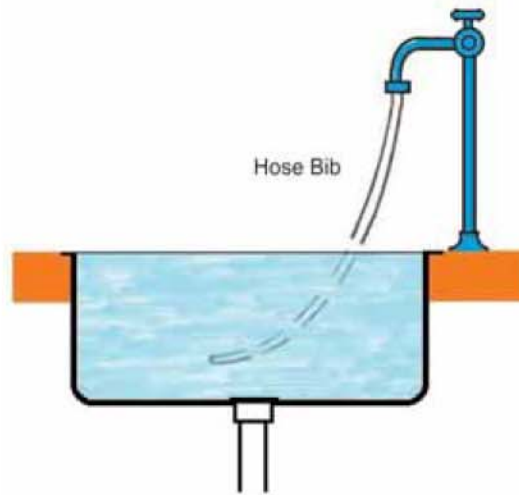

**Figure 2.3:** Back Siphonage

#### 2.4 Backwater Valve

Backwater valves are commonly installed on drainage connections from individual properties to public sewers. Excessive flow in the public sewer and build-up of sewage levels due to blockage and/or ingress of rainwater into the public sewage system causes back flow of sewage into the individual premises. A backwater valve would allow flow only in one direction—from the individual property to the public sewer. When the premises are unused for long periods the back water valve can be locked in closed position so that back flow does not occur when the premises remain unattended. Backwater valves will also prevent entry of rodents from the public sewer into private premises.

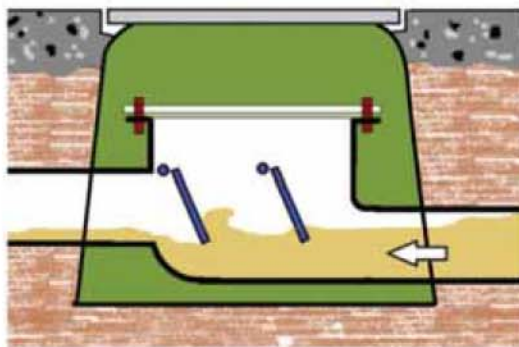

(Note: Arrow indicates backflow)

**Figure 2.4:** Backwater Valve

#### 2.5 Cesspool

Cesspools, although not desirable, are often constructed for disposal of sewage from small dwelling units. Cesspools are meant to retain solids from the sewage, permitting the liquid to percolate into surrounding soil.

In unavoidable situations, especially of temporary nature, cesspools are constructed by excavating a pit (with partial lining with perforations or without lining) to receive drainage from small premises such as individual homes, construction site offices, mobile homes, etc. Cesspools should never be constructed near sources of potable water such as open wells, tube wells, underground storage tanks or in locations of high water table. Since cesspools are for temporary usage for limited period, they should be filled up after ensuring adequate disinfection.

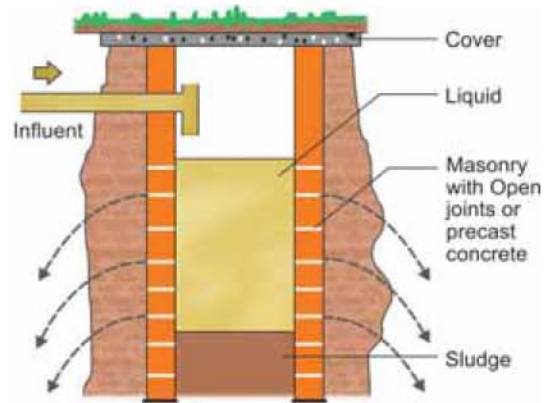

Figure 2.5: Cesspool

## 2.6 Cross Connection

For the purpose of conserving water, government regulations stipulate usage of alternative water sources for non-potable applications in large projects. Additionally, in properties desiring Green Building Certification, such systems are mandatory. Non-potable applications include flushing of toilets and urinals, landscape irrigation systems, etc. If adequate care is not exercised, cross connections can occur by inadvertent connections between pipes carrying potable and non-potable water causing serious health hazards.

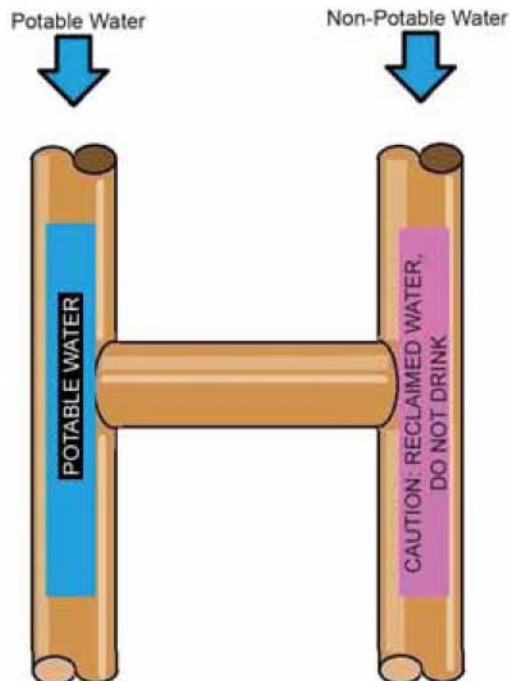
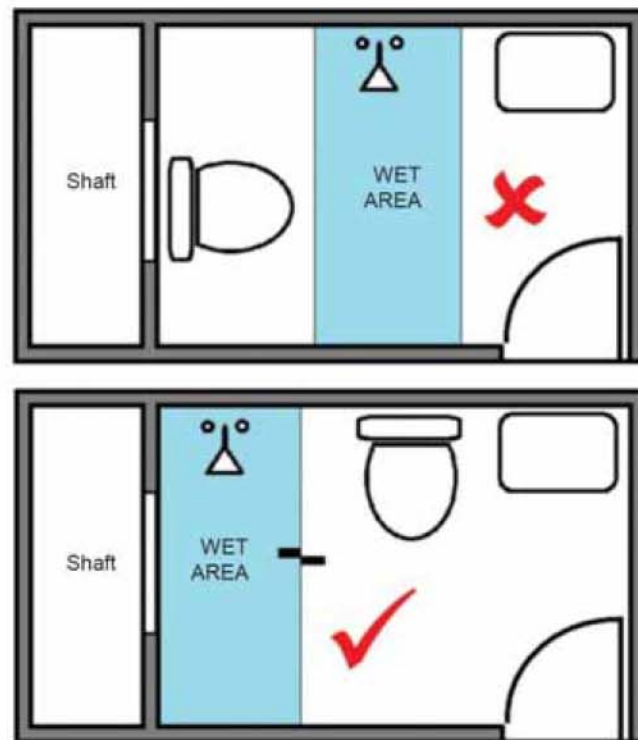

Figure 2.6: Cross Connection (Hazardous)

## 2.7 Dry/Wet Area

While designing washrooms with showers, layout of fixtures should be such that dry and wet areas are clearly segregated. This can be accomplished by locating the shower area in a discreet manner preferably with a recessed floor (away from the water closet and wash basin), creating a shower cubicle using glass/acrylic panels or a shower curtain. Such segregation is particularly important if the wash room is to be used by the elderly and the children, to prevent accidental fall due to slippery floors.



*Figure 2.7: Dry and Wet Areas*

## 2.8 Fixture Unit

Fixture unit values are used by plumbing professionals for calculation of pipe sizes, selection of equipment, etc. These values have been derived after extensive research and are different for water supply and drainage systems. Different plumbing codes and design guides use fixture units of different values and they should not be cross referenced.

## 2.9 Float Valve

Float Valve (sometimes called Ball Valve) is a device used for controlling water levels in storage tanks. It is always recommended to install an isolating valve before the float valve since the latter will require periodic cleaning and maintenance. There are low pressure and high pressure float valves using different internal mechanisms.

It is important that the appropriate one is chosen depending on the working pressure in the water connection.

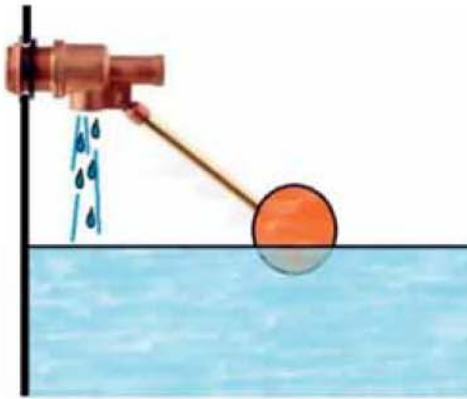

Figure 2.9: Float Valve

### 2.10 Flush Valve

Flush valve is one of the devices used for flushing of water closets and urinals. Minimum working pressure, larger pipe sizes, effects of water hammer, probable larger consumption of water etc should be considered while deciding to opt for flush valves. A flush valve is always installed with an isolating valve/stop cock to facilitate maintenance. A flush valve should also have a vacuum breaker at the outlet in order to prevent back siphonage from the water closet pan or urinal bowl into the water distribution system. Several products currently marketed do not comply

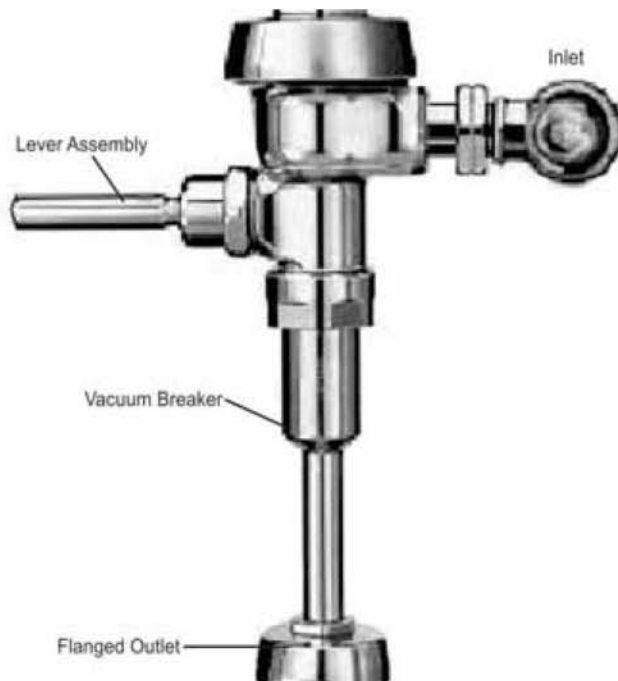

Figure 2.10: Flush Valve

with these requirements and are flush cocks wrongly termed as flush valves. Flush valves are more prone to malfunction and require skilled plumbers to repair. Models with dual flushing mechanism should be preferred for conservation of water.

### 2.11 Flush Tank (Flushing Cistern)

Flush tank is a device used for flushing of water closets. Flush tank can be installed in a number of ways such as integral with the water closet pan, low level or high level with a flush pipe between the flush tank and the water closet pan, concealed cistern, remote operated pneumatic cistern, electronically operated cistern, etc. Integral flush tanks can also be close-coupled with the pan or one-piece unit consisting of the cistern and the pan. Models with dual flushing mechanism should be preferred for conservation of water.



**Figure 2.11a:** Flush Tank



*(Note: Not recommended)*

**Figure 2.11b:** Auto Flushing Tank

In the past, automatic flushing cisterns were used for urinals. This is generally discontinued now as automatic cisterns are known to cause wastage of water as the flushing operation takes place even when the urinals are not in use.

### 2.12 Gully Trap

Gully trap is installed external to the building, in open courtyards, etc. in a masonry chamber to receive drainage from waste pipes prior to their connection to the external sewer. There are several methods of drainage installations recommended by plumbing codes of various countries. Gully trap is used in a two pipe drainage system (with separate pipes to carry black and grey water), commonly used in India. In these cases, waste appliances such as wash basins and sinks are trapped thrice

and in-situ showers are trapped twice prior to their discharge into the external sewer. These methods are considered additional precautions because of the reservations on the correctness of some of the fixture traps available in the domestic market. Plumbing codes stipulate a minimum of 50 mm water seal in a fixture trap and several models available often do not comply with this requirement.

While the conventional gully trap used to be of stoneware construction, gully traps in sealed drainage systems using cast iron, uPVC, etc. can have a trap with a gully inlet instead of a masonry chamber.



*Figure 2.12: Stoneware Gully Trap*

### 2.13 Interceptor

Interceptors (separators) are used in drainage installations to prevent undesirable elements such as oil, grease, sand, etc. entering the sewers and thereby causing blockages. Interceptors, wherein these elements are trapped and removed separately, are installed prior to connection of drainage pipes from large kitchens, parking lots, fuel stations, health clubs, etc. to the main drainage system. There are several types that can be used including in-situ constructed units, engineered and pre-fabricated units, etc. Advice of a plumbing professional should be sought for selection and installation of interceptors.

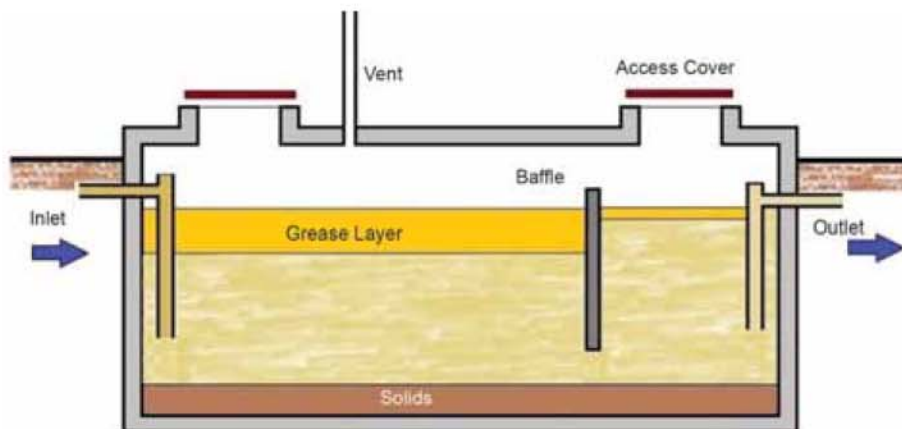

*Figure 2.13a: Grease Interceptor (In-situ)*



*Figure 2.13b: Grease Interceptor–Installed*

#### 2.14 Inspection Chamber/Manhole

As the term suggests, inspection chambers are provided for periodic inspection and maintenance of external drainage systems. These are located at changes of direction of the drains, to receive branch connections and to accommodate substantially different invert levels of inlets/branches and outlets. Inspection chambers shall be provided at regular intervals not exceeding 30 meters and relatively shallow sewers not exceeding 900 mm in depth where the inspection can be accomplished without entering the chamber. In deeper installations, manholes are provided wherein the operatives may enter for inspection and maintenance. Inspection chambers and manholes shall be adequately ventilated in order to protect the maintenance staff against possible suffocation caused by dangerous sewer gases. Inspection chambers and manholes are provided with suitable precast concrete/cast iron/ductile iron/fiber reinforced plastic/polypropylene/polymer composite frames and covers. The likely load from traffic shall be taken into consideration to select the appropriate covers. Inspection chambers/manholes if constructed within building premises shall have air tight frames and covers.

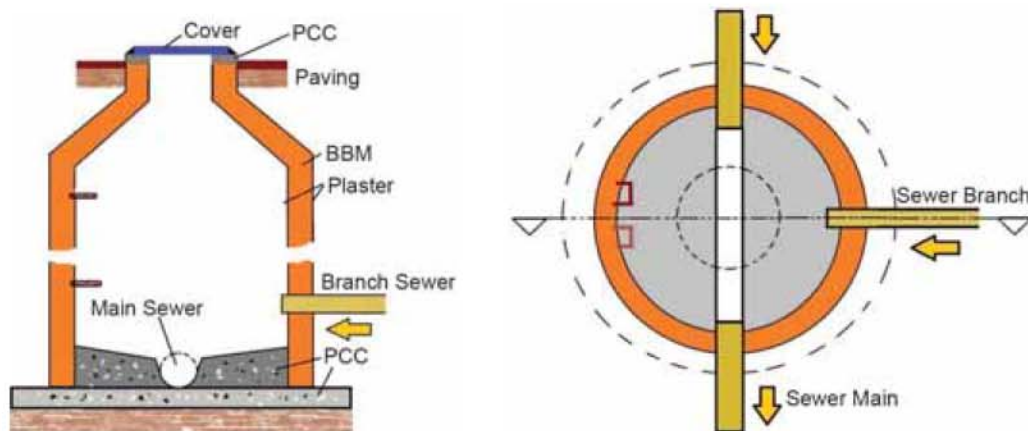

*Figure 2.14: Manhole*



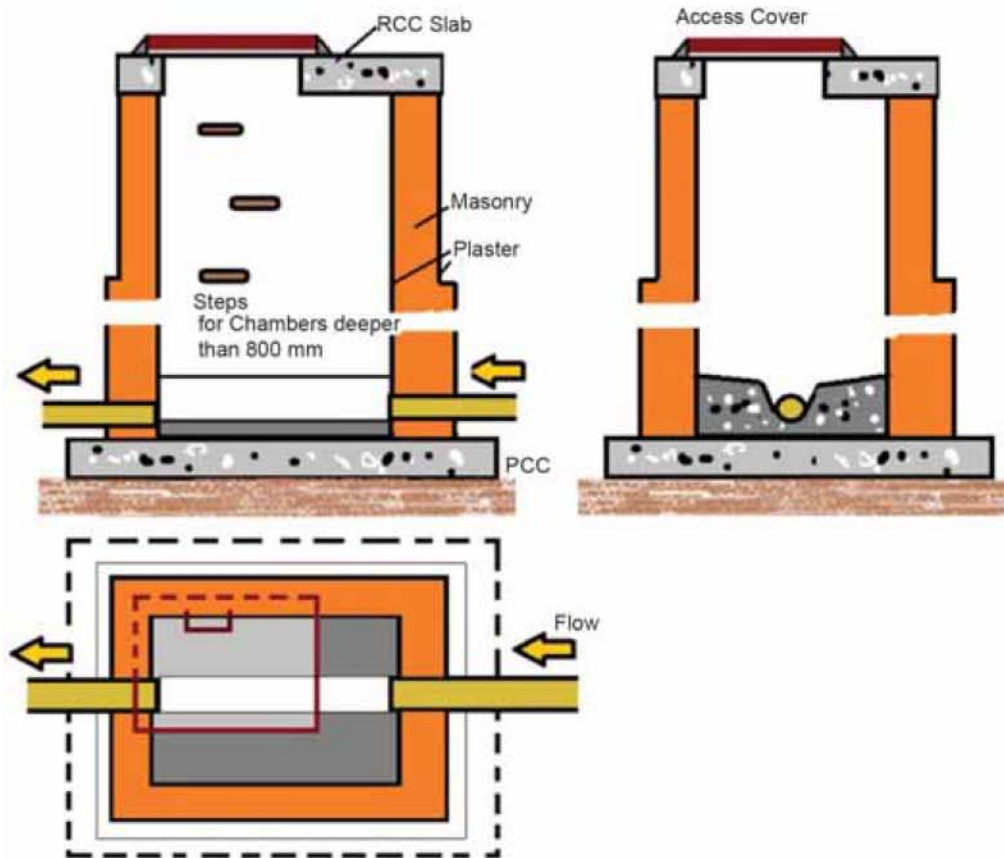

Figure 2.14a: Inspection Chamber (in-Situ)



Figure 2.14b: Plastic Moulded Inspection Chamber

### 2.15 Potable Water

The term potable water refers to water that is suitable for human consumption and shall include usage such as drinking and cooking. However, any water that comes into contact with human body such as at wash basins, showers shall also be of appropriate and adequate quality.

### 2.16 Push Tap

Push tap is a terminology commonly used for mechanically operated metered faucets where a pre-determined quantum of water is discharged in each operation. These are generally used in public wash rooms in order to conserve water. These taps are usually calibrated at the factory to a pre-determined flow volume.



*Figure 2.16: Push Tap (Mechanically Operated)*

### 2.17 Sensor Operated Faucet

Sensor operated faucets facilitate hygienic usage at wash basins in public toilets as human contact is completely avoided. These are also designed for conservation of water as misuse is prevented. These faucets are available with provision of only cold water or hot and cold water using a remotely installed mixing unit. Sensor operated faucets will require minimum working pressures for which manufacturer's recommendations shall be referred to.



*Figure 2.17: Metered Faucet (Electronically Operated)*

### 2.18 Septic Tank

A septic tank is used for treatment and disposal of domestic sewage, except in large occupancy buildings. When designed and constructed correctly these can work satisfactorily in conjunction with soak pits, up-flow filters or dispersion trenches using perforated pipes.

Septic tank installation described above shall not be in the vicinity of water sources such as open wells, tube wells, storage tanks, etc. to ensure that contamination of water sources does not occur.

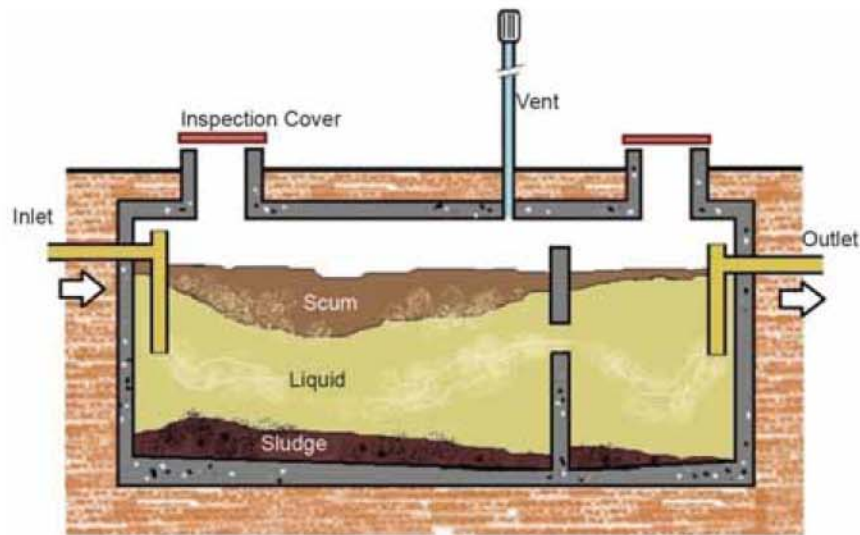

Figure 2.18: Septic Tank

### 2.19 Single Lever Mixer

Single lever mixer regulates flow of hot and cold water using a common handle. Single lever mixer requires a minimum working pressure for satisfactory operations and is not recommended in installations depending solely on gravity flow from an inadequately elevated water tank. Single lever mixers are available for use at wash basins, sinks, showers, bath tubs, etc.



Figure 2.19a: Single Lever Mixer-Shower



Figure 2.19b: Single Lever Mixer-Wash Basin

## 2.20 Slope

A slope, also called gradient, is a vertical drop/fall in a horizontal plane, expressed in ratio or percentage. A slope is what facilitates flow in a gravity drain. Inadequate and incorrect slopes can result in malfunctioning of gravity drains.

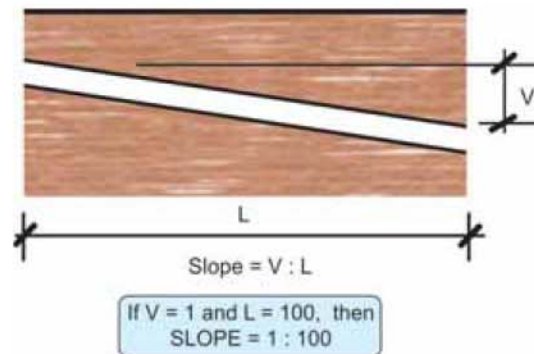

*Figure 2.20: Slope*

## 2.21 Static Head

Static head in plumbing installation is defined as the vertical distance/elevation between two points in a water distribution system, expressed in meters. Static head is one of the parameters in determining selection of pumps.

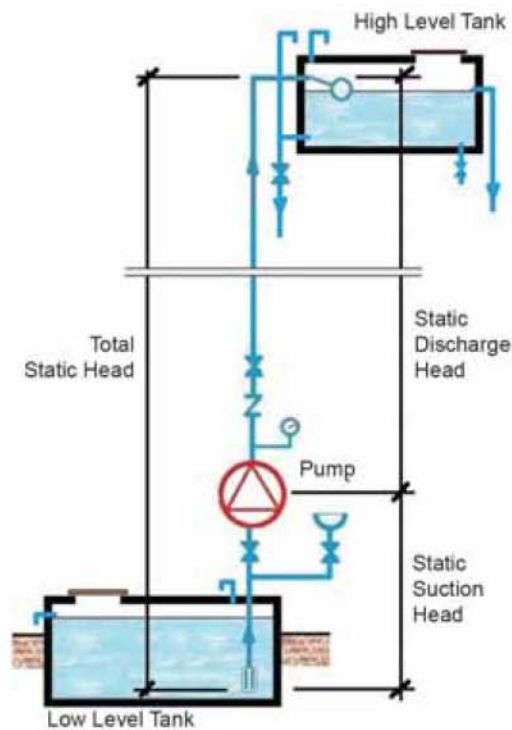

*Figure 2.21: Static Head*

## 2.22 Strainer

Strainers are usually provided on the suction end of pumps, outlets from water tanks and before appurtenances such as pressure reducing valves, water meters, etc. Strainers installed on plumbing pipes are usually two types namely pot strainer and Y strainer. The mesh within the strainer should be periodically removed, cleaned and replaced for satisfactory operation.

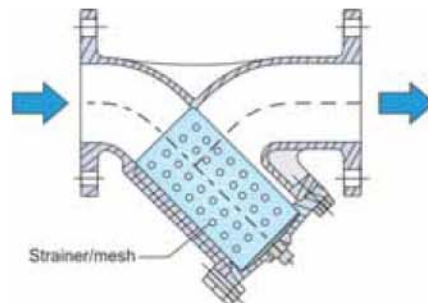

*Figure 2.22a: Strainer-'Y' Type*

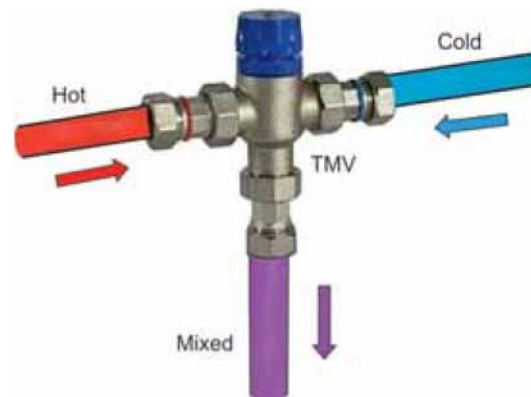

*Figure 2.22b: Strainer-Pot Type*

## 2.23 Thermostatic Valve

Thermostatic valve used in plumbing installation blends hot and cold water and delivers at a pre-set temperature. These valves will assist in prevention of dangerous consequences of scalding and wastage of cold water while adjusting temperature of hot water for user comfort. Modern plumbing codes stipulate thermostatic mixers to have built-in temperature and pressure balancing devices to prevent thermal shocks apart from scalding accidents.

Thermostatic valves are available for use at individual draw-off points or as a common valve for a group of fixtures. A common thermostatic valve is recommended on solar hot water system where the temperature generated can be far in excess of safe and permissible limits.



**Figure 2.23:** Thermostatic Mixing Valve (TMV)

## 2.24 Trap

Traps are devices installed on drainage systems for prevention of sewer gases from entering living premises. Traps are provided with a prescribed depth of water (water seal) which has to be constantly retained to prevent sewer gases from entering the premises through the pipes. Traps not receiving flow from fixtures or traps installed for emergency purposes (without receiving flow from fixtures) should be regularly monitored to ensure requisite depth of water seal as the same gets evaporated over a period of time. Minimum and maximum depths of water seal prescribed by Uniform Illustrated Plumbing Code-India are 50 mm and 100 mm respectively. In situations where fixtures are not drained into traps, trap seal primers can be installed to ensure presence of water seal.



**Figure 2.24:** Trap

A trap seal primer is piped from an adjoining water distribution system from which a few drops of water are discharged into the trap each time the distribution system is in use. This is an engineered product not manufactured in India at present.

### 2.25 Vent Pipe

A vent pipe is an integral part of a drainage system to ensure maintenance of atmospheric pressure within the pipes thereby preventing trap siphonage and backpressure. A vent pipe ensures safe release of gases generated within the system and prevents positive pressure being built up. It also allows entry of fresh air to offset negative pressures.

Devices such as air admittance valves and positive air pressure attenuators (PAPAs) are also available to replace conventional vents. When used in conjunction these might provide the desired results. These products are presently not manufactured in India and are expensive when imported.



*Figure 2.25: Air Admittance Valve*

### 2.26 Water Hammer

Water hammer is a phenomenon experienced in distribution systems and is noticed as a loud repetitive noise. Water hammer can result in vibration of pipes, displacement of pipe supports, shaking of faucets and in extreme cases bursting of pipes.

Water hammer is caused by sudden stoppage of flow of water in a pipe as a result of quick closing of a valve, stoppage of pump, etc. Water flow back and forth within the pipe in these situations creates excessive velocities which will continue until a relief is found by way of an air chamber to absorb the pressure surges.

Conventional methods to absorb water hammer used to be provision of air chambers which have been proven ineffective. Engineered water hammer arrestors which contain pre-charged diaphragms offer an effective solution to this

phenomenon. Water hammer arrestors shall be sized appropriately using the fixture unit methods to determine their required capacities.

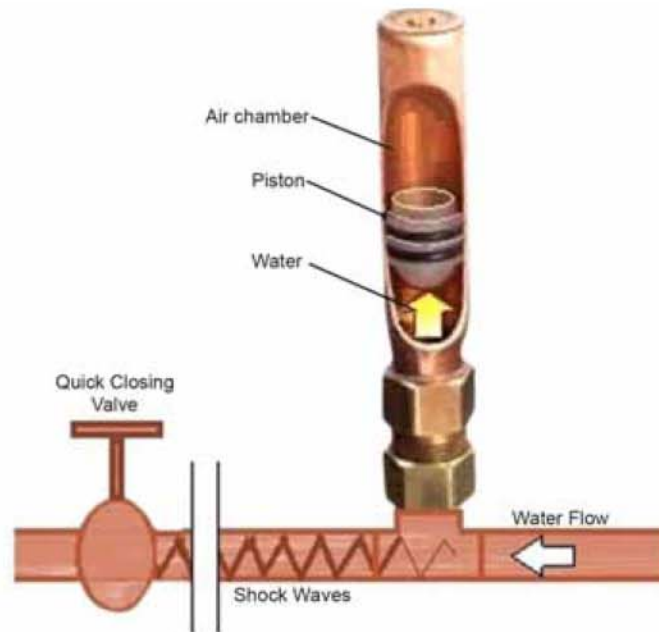

*Figure 2.26: Water Hammer Arrestor*

### 2.27 Water Level Controller

Water level controllers are used for facilitating the operation of pumps for automatic filling of storage tanks. Level sensors provided at pre-determined high and low levels within water tanks dictate starting and stoppage of pumps. Sensors are also provided in suction tank to prevent dry running of pumps in the absence of water in the tank.

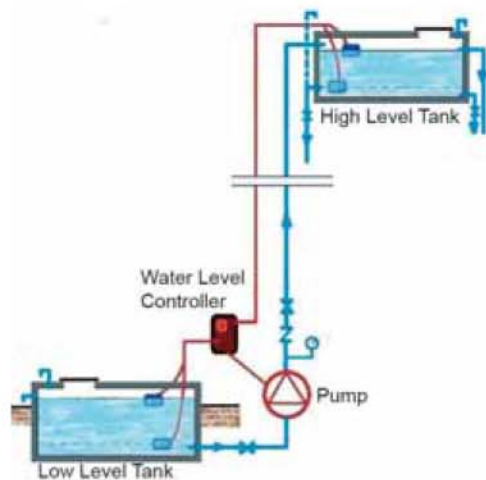

*Figure 2.27: Water Level Controller*



### 2.28 Water Pressure

Water pressure is the force required to ensure desired flow of water at user points. Water pressure in distribution systems is commonly generated by static heads from elevated tanks. Where the pressure thus generated is found inadequate, booster pumps are installed. Fixtures such as single lever mixers, thermostatic mixers, flush valves, etc. require a minimum working pressure for satisfactory operation. UIPC-I stipulates minimum and maximum working pressures of 0.5 bar (5.00 meter water column) and 5.5 bar (55 meter water column) respectively. Where ablution faucets with hand held trigger spray are used, very high working pressures will be uncomfortable for usage. In such cases, simple aerators for pressure and flow regulation can be installed at the ablution faucets.

# Basic Planning for Plumbing

## 3.1 Location of Washrooms, Kitchens and Utility Areas

3.1.1 As far as possible, facilities such as washrooms, kitchens and utilities should be located in close proximity to minimize pipe work and other associated plumbing installations. Wash rooms and kitchens should preferably be located towards the external faces of the building to ensure natural light, ventilation and ease of pipe work.

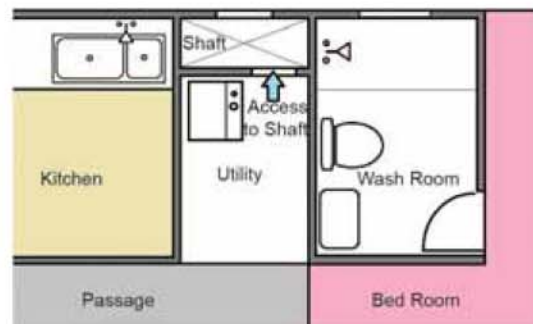

Figure 3.1.1: Location of Wet Areas

3.1.2 In multi-storied buildings these facilities should ideally be stacked one above the other so that location of plumbing shafts and pipe work therein can be simplified.

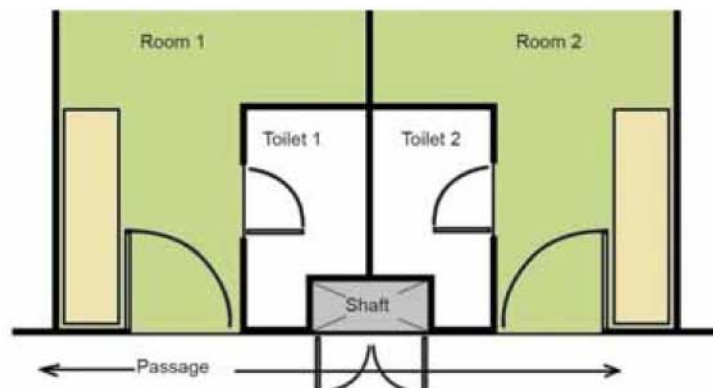

Figure 3.1.2a: Location of Shaft



Figure 3.1.2b: Location of Shaft

3.1.3 Plumbing shafts should be located in close co-ordination with the layout of plumbing fixtures within wash rooms, kitchens, etc. Shafts should be truly vertical, continuous and preferably of the same size from the lowest point (basement, ground floor, etc.) to the roof. Plumbing shafts will require access at every floor level. Where possible, shafts should be located with entry from common areas of the building so that access for maintenance can be availed without having to enter private spaces. Determination of locations and sizes of plumbing shafts should be in consultation with the plumbing professional, from the planning stage.

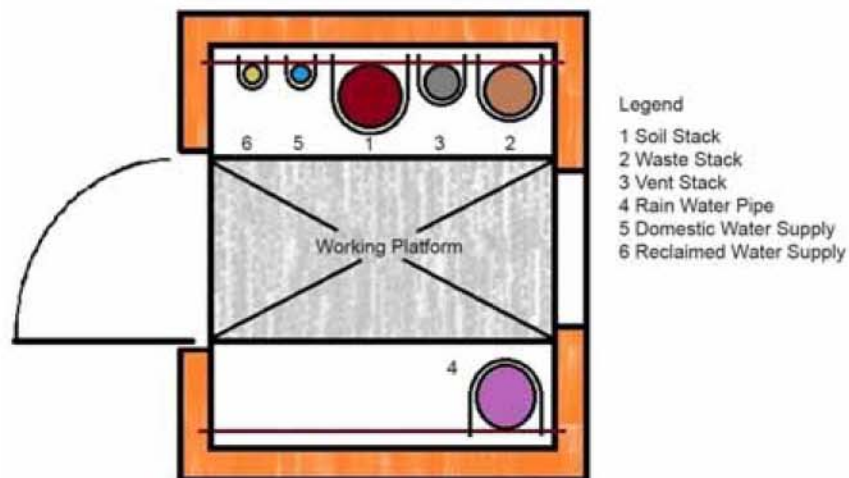
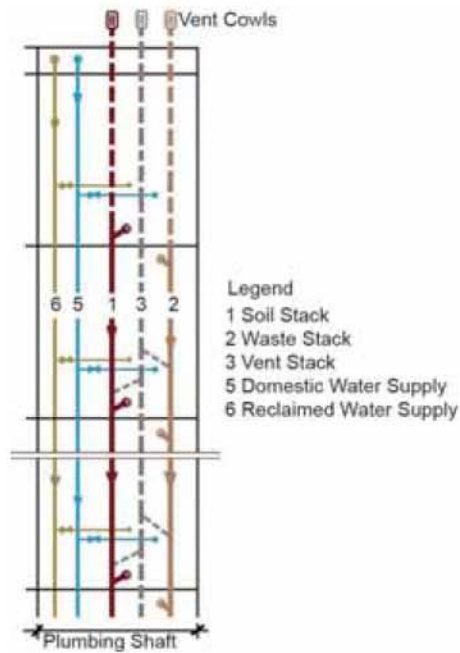

Figure 3.1.3a: Plumbing Shaft-Plan



*Figure 3.1.3b: Plumbing Shaft-Elevation*

3.1.4 Obstructions by structural members such as beams, columns within plumbing shafts must be avoided.



*Figure 3.1.4: Structural Obstructions in Shaft-Section*

**3.1.5** Size of plumbing shaft should be decided based on the number of services to be installed within. Co-ordination with other services such as Heating, Ventilation and Air-conditioning (HVAC) pipes and ducts should be done at the planning stage. Regulations do not usually permit installation of firefighting, cooking gas and electrical services within plumbing shafts and therefore separate shafts must be provided for these. In high-rise structures (where access to shafts cannot be achieved through portable ladders) provision shall be made in the form of cat ladders/rungs and platforms at floor levels within the plumbing shaft for the operatives to attend to repair and maintenance.

**Table 3.1 Services in Plumbing Shaft**

List of Services in Plumbing Shaft	
1.	Cold Water Supply, Domestic
2.	Cold Water Supply, Flushing
3.	Hot Water Supply
4.	Hot Water Return
5.	Isolation and Regulating Valves for above
6.	Domestic Water Riser to OHT
7.	Flushing Water Riser to OHT
8.	Rain Water Leader (Down-take)
9.	Soil Stack (one or more)
10.	Waste Stack (one or more)
11.	Vent Stack (one or more)
12.	Shaft drain and drain stack
13.	Access Door from Toilet/Passage
14.	Toilet Exhaust
15.	Working Platform
Additional Services Accommodated in Plumbing Shaft	
16.	Water Heaters
17.	Flush Tanks or Flush Valves
18.	HVAC pipes
19.	Artificial Ventilation
20.	Artificial Lighting



**Figure 3.1.5: Shaft Details with Multiple Services**

**3.1.6** Fire regulations for high rise structures will require sealing of internal plumbing shafts at every floor level. In such cases, shaft drains at every floor level may be provided. Shaft drain may be necessitated to cater to dripping of water from air valves, small leakages and also to receive condensate from air conditioning units. Unsanitary conditions may occur due to evaporation of water seals in unused traps of shaft drains. Periodic replenishment of water seal in traps may therefore be necessary.

### **3.2 Sizes of Washrooms, Kitchens and Utility Areas**

**3.2.1** Minimum sizes of washrooms, kitchens, and utility areas should be determined based on the types and numbers of fixtures and their preferred layouts within. While wash rooms and utility areas shall predominantly have plumbing fixtures and appliances such as cloth-washers, cloth-dryers, etc. additional consideration will be required while sizing kitchens. Kitchens will require space for provision of dish washers, refrigerators, cooking ranges, ovens, working platforms, etc. apart from sink(s) and storage cabinets. Therefore close co-ordination will be required between the end-user, the architect, the interior designer and the plumbing professional.

**3.2.2** A typical residence will usually have bathrooms, shower rooms and powder rooms (toilets). While sizing a bathroom with a bath tub, the size of the tub is of extreme importance as these are available in different sizes, the smallest ones usually of 750 mm width and 1500 mm length. The other fixtures shall include a water closet, a vanity or a wall mounted wash basin and in some cases a bidet.

**3.2.3** In the case of shower room there can be an *in-situ* shower area and a pre-engineered, ready to install shower cubicle, in some cases incorporating shower tray, apart from the water closet and wash basin.

**3.2.4** A powder room or a toilet shall have a water closet and vanity or wall mounted wash basin.

**3.2.5** The UIPC-I provides information on minimum spaces required around plumbing fixtures to ensure user comforts. Referring to these and also taking into account the fixtures described above, it will be seen that a rectangular shape is preferred over a square shape. A bathroom or a shower room of a minimum finished length of 2250 mm and width of 1650 mm will facilitate installation of bath tub/shower, a water closet and a wash basin with reasonable user comfort. This takes into consideration a clear width of 800 mm for bath tub/shower, 850 mm for the water closet (with 425 mm from the center to either sides) and 600 mm for wash basin. The length of 1650 mm also takes into account ease of locating the door and opening of the door shutter without obstacle.

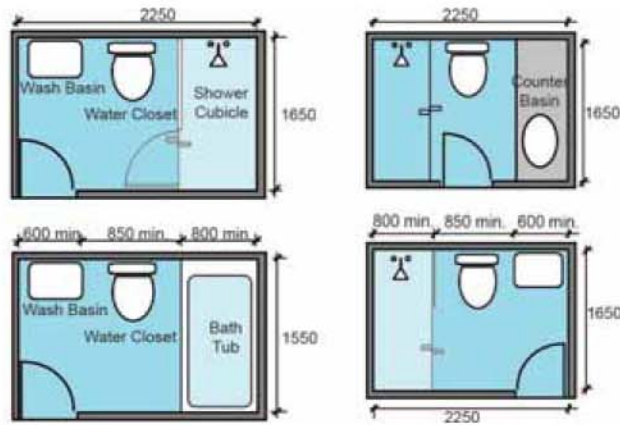

Figure 3.2.5: Washrooms (Alternative Layouts)

3.2.6 Shape of a powder room/toilet consisting of a water closet and a wash basin can be square or rectangular with minimum sizes of 1500 mm × 1500 mm or 1000 mm × 1650 mm or 2250 mm × 1650 mm. Shape of a room with water closet can be rectangular with a minimum size of 900 mm × 1500 mm.

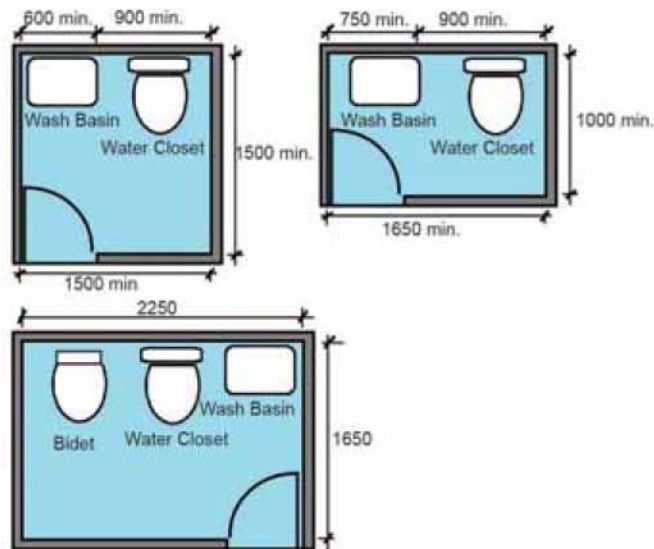

Figure 3.2.6a: Powder Room (Alternative Layouts)

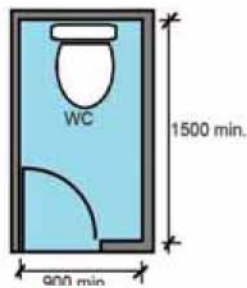

Figure 3.2.6b: Water Closet Room

**3.2.7** The sizes provided above are indicative. An architect or an interior designer may opt for contemporary layouts and designs of wash room interiors in which case customized sizing of these facilities will be necessary.

**3.2.8** Fixing/mounting heights of the washroom fixtures are generally considered uniform in India although minor variations may be implemented by individual designers/end users. Some of the commonly adopted dimensions are as follows:

- European water closets-Wall mounted (including Seat)-375 to 425 mm
- Wash basin (up to rim)-800 to 850 mm
- Kitchen/Utility sink-800 to 850 mm
- Bowl urinal (up to lip)-500 to 600 mm
- Shower mixer-750 to 1000 mm
- Shower head-1800 to 2100 mm
- Bath spout (above top of tub)-100 to 150 mm
- Ablution faucet-400 to 450 mm

The dimensions are with reference to the finished floor level.

Mounting heights suggested above will vary for children. A separate section is included in this publication for toilets/washrooms for the differently abled.

Floor mounted water closets, full stall urinals and wash basins with full pedestals will have pre-determined mounting heights.

Heights of flush valves for water closets shall be determined based on the types of valves used and in conjunction with the closet pans ensuring that the seat cover when upright is not obstructed. A similar consideration may be given in determining heights of actuator plates of concealed/pneumatic flushing cisterns.

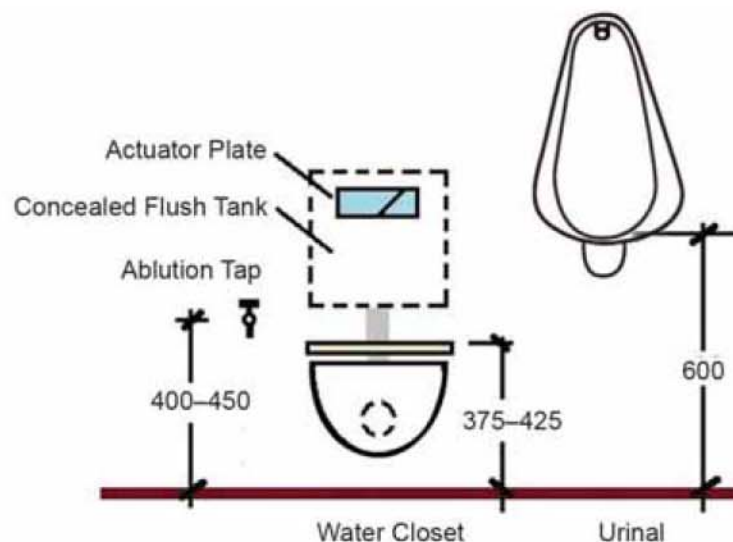

**Figure 3.2.8a:** Mounting Heights



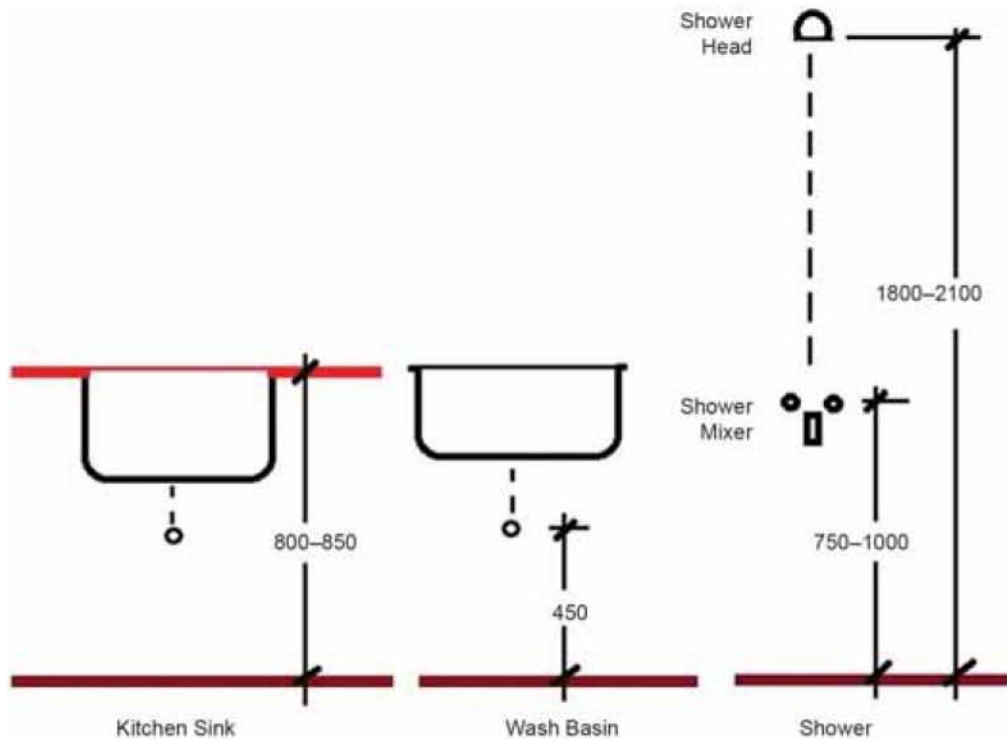

Figure 3.2.8b: Mounting Heights

### 3.3 Plumbing Fixtures and Fittings

**3.3.1 General** - Plumbing fixtures and fittings include water closets, bidets, wash basins, bath tubs, showers, sinks, water heaters, ablution faucets, sink and wash basin mixers and wash room accessories such as towel racks, towel rails, towel rings, toilet paper holders, soap dishes, robe hooks, cloth lines, shower curtain rails, etc.

Public toilets will additionally have urinals, soap dispensers, hand dryers, mop sinks, etc. Generally, drinking water station is also located outside the public toilets.

Prior determination of models and types of fixtures to be used, especially in the case of water closets with their flushing devices, wash basins, bath tubs and shower mixers is of extreme importance. The plumbing connections and subsequent designs of plumbing system will largely depend on this information.

**3.3.2 Water Closet** - Water closets commonly used include the European, Asian/Indian (squatting) and Combination types.

European water closets are differentiated by the mechanism of flushing and/or method of mounting. There are two types of flushing action namely siphonic (where the flushing happens through siphonic action due to the specific design and construction of pan) and wash down (where the flushing action happens through the force and volume of water used).

European water closets can either be floor mounted or wall hung. Wall hung closets facilitate cleaning of the floor below the pan. While installing wall hung

closet pans, additional precautions to ensure correct height and fixity to the wall are to be ensured. Use of purpose made carrier frames is recommended. There are models which are to be mounted on to the wall using expansion bolts. In such cases the stability of the wall needs to be ensured and in some cases additional concrete blocks may have to be provided to receive the expansion bolts.



**Figure 3.3.2a:** Water Closet-Wall Mounted



**Figure 3.3.2b:** Water Closet-Floor Mounted



**Figure 3.3.2c:** Water Closet-Floor Mounted (One Piece Unit)

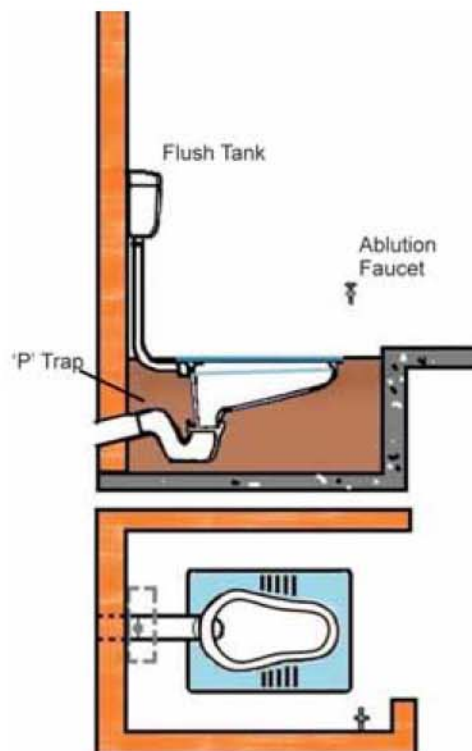

**Figure 3.3.2d:** Indian/Asian Water Closet (Squatting Pan)



*Figure 3.3.2e: Combination Water Closet*

In most cases, European water closets will have flushing mechanisms as integral parts of the water closet suites. Asian/Indian (squatting) pans will have detached flushing devices. Care shall be taken to ensure that the cistern and the pan function efficiently in conjunction. European water closets have integral traps whereas in the case of Asian/Indian (squatting) pans, appropriate compatible traps shall be added.



*Figure 3.3.2f: Indian Water Closet with Trap*

Flushing mechanism for water closet can be a cistern or a flush valve as described in Chapter 2.0. In cases where flushing mechanisms are not part of the toilet suites and are selected separately, the compatibility of the pan and the flushing device should be ensured.

European and Combination water closets come with seats and covers of various materials such as plastics, ABS, wood, etc. They are also available in soft close option for European water closets.

**3.3.3 Ablution Fixtures** Asians have always considered water to be essential for ablution due to hygiene considerations. In the past a bib tap used to be provided next to water closets whereas the current trend is to use a hand-held trigger spray with a flexible hose and a stop cock, usually located on the right of the user when seated.

Various models of water closets are currently available with ablution sprays integrated with the closet seats and independent units added under the seats. Available information on these products does not indicate incorporation of a back flow prevention device into these units. In the absence of an appropriate back flow prevention mechanism these units may cause contamination of the water distribution system as these are in close proximity with the water closet pans.

Since the ablution device described above needs to be connected to the domestic water distribution system serving wash basins, showers, kitchen sinks and drinking water sources, occurrence of back siphonage may cause serious health hazards due to contamination.

**Note:** Several researches have established that manufacturing of toilet paper involves environmental degradation due to deforestation as timber is used as the basic raw material. Additionally, research by the plumbing industry has established that, toilet paper as one of the prime causes for blockage of drains especially in the current scenario when the focus is on water conservation through low flow fixtures. A decrease in flow of water in drains and the addition of toilet paper with high wet density adversely affects the self-cleansing velocity in the drainage system. Consequently this aggravates the problem commonly termed by the plumbing professional as 'Dry Drain Phenomenon'. When this occurs there is a tendency for the liquid to flow without carrying the solids along with it leading to blockage.

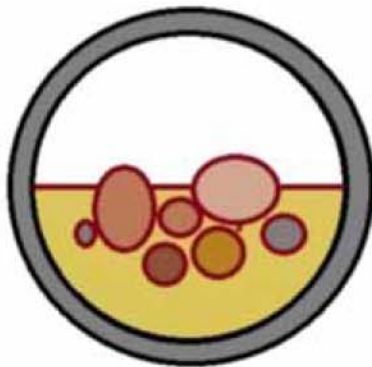

**Figure 3.3.3a:** Adequate Cleansing Velocity

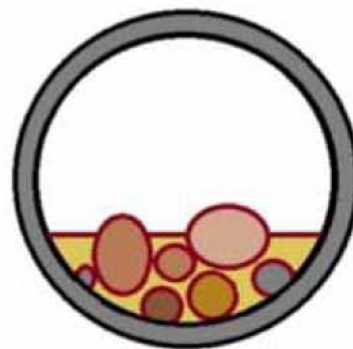

**Figure 3.3.3b:** Inadequate Cleansing Velocity

**3.3.4 Bidet** Bidets are ablation fixtures manufactured in vitreous china, installed in close proximity to water closets. Bidet can be floor mounted or wall mounted to match the design of the water closet pan.



*Figure 3.3.4: Bidet*

Bidet mixers with spray heads are now discontinued due to concerns of contamination of water distribution system through the submerged spray heads. Currently bidet mixer is deck mounted with a spout. Bidet outlets are recommended to be connected to the soil drainage system with appropriate traps. UIPC-I stipulates a relatively lower temperature for blended water for usage in bidet in comparison to the other fixtures.

**3.3.5 Urinals** Urinals currently available are categorized as bowl urinals and stall urinals. Trough urinals are prohibited fixtures as per provisions of UIPC-I.



*Figure 3.3.5a: Trough Urinal (Not Recommended)*



*Figure 3.3.5b: Urinal with Sensor*



**Figure 3.3.5c:** Urinal with Flush Valve

Flushing mechanisms used with urinals are flush valves or sensor operated electronic flushing devices. When flush valves are used a vacuum breaker shall be an integral part of the unit. Where alternative water sources are used for flushing, the same shall be provided for flushing of urinals. The flushing device should be appropriate for usage as an integral part of the urinal, in terms of flush volumes delivered. Urinals are always connected to the soil drainage system.

Waterless urinals are currently used as a means towards water conservation. Waterless urinals incorporate cartridge, a floating liquid or a mechanical device to replace a water seal used in conventional urinals. Water Efficient Products - India (WEP-I), an IPA-IAPMO publication, stipulates several precautions to be considered while using waterless urinals.

### **3.4 Safety Features**

#### **3.4.1 Selection of Materials**

Sanitary fixtures manufactured of impervious materials such as vitreous china, fire clay, glass, stainless steel, or plastics of approved quality, etc. shall only be used.

Selection of vitreous china sanitary ware should take into account the quality of glazing, as substandard glazing will encourage microbial growth. Consequently only those products which are BIS certified or equivalent shall be chosen.

The flooring material chosen shall be of non-skid type but at the same time facilitating smooth flow of water.

The fasteners/brackets shall be chosen with care with due reference to manufacturers' recommendations. It is recommended that the walls of toilets/wash rooms be built with bricks/solid blocks instead of hollow blocks to ensure adequate stability of the fixture. As an additional measure of safety, concrete bands/blocks of adequate width and depth may be provided where fasteners are used.

#### **3.4.2 Installation**

Installation of fixtures in washrooms shall be such that free access and movement shall not be obstructed. Washroom accessories such as toilet holders shall not protrude into the minimum space stipulated earlier in this publication for water closets. Similarly, installation of a soap dish/dispenser in a confined space of a shower cubicle shall be such that free body movements are not impeded. Towel racks/towel rails, etc. over the bath tub should be suitably located to avoid accidental injuries to the user or obstruct movement of door shutter.

Grab bars at showers/bath tubs/water closets, etc. shall be adequately secured ensuring safety of the user.

# Water Supply

## 4.1 Estimation of Daily Water Requirement

**4.1.1** Estimation of daily water requirement will be the primary step in design of a plumbing system. Various plumbing codes, standards and other publications provide differing data which will need to be evaluated for specific applications. In addition to the published data available, experienced engineers involved in the operation of large properties such as hotels, hospitals, commercial/residential complexes and mixed occupancy buildings maintain their own data which may be in variance with the published data.

**4.1.2** Considering the differing data available from multiple sources, plumbing engineers generally rely upon the stipulations of the National Building Code of India (NBC) published by BIS for per capita daily consumption. As an example, the NBC recommends 135 Liters per capita per day (lpcd) for a residential building. Where alternative water sources are available, one-third of this quantum used for flushing purposes will be from that source, to reduce the burden on the potable water source. Water consumption data mentioned here may have to be revised upward for high end residential properties with bath tubs, swimming pools, water bodies, extensive landscaping, etc.

In the case of office complexes, the NBC recommends 45 lpcd which comprises requirement of flushing and domestic applications. Water consumption by visitors shall be added to this requirement at the rate of 15 lpcd. Large office complexes with food courts need to consider additional 70 liters per day per seat.

**4.1.3** The second important step in assessing probable daily water consumption will be the estimation of occupancy levels of the building under consideration. In the case of single family residential unit, the standard method of calculation will be 5 occupants per unit. In the case of high end residences, additional occupancy may be considered for domestic staff.

Occupancies in office complexes are generally calculated considering 1 person per 10 m<sup>2</sup> of built up area, unless otherwise defined by the end users.

## 4.2 Water Sources

**4.2.1** Sources of water are generally from government agencies, public utilities, on site open wells, bore wells, rivers, lakes, etc.



4.2.2 Alternative source of water may include harvested rainwater and recycled/reclaimed waste water from treatment plants. Catchment area of rainwater for reuse within buildings should be restricted to the roof tops. Provision shall be made for flushing away water collected during initial rains. Rainwater harvested from lawns, building surroundings, roof gardens, balconies, etc. may be used for recharging the ground water table through recharge pits.

4.2.3 Use of alternative water (recycled water from STP) for flushing is not recommended in hospitals and other health care facilities. When treated effluent is used for landscaping purposes in premises used by children such as schools, additional precautions like colour coding of pipes, visible identification labels, lockable draw-off taps (to prevent unauthorized/un-intended usage), etc. shall be strictly implemented. Modern plumbing codes such as UIPC-I provide required information on stringent precautions to be taken when using alternative water sources in any kind of premise.

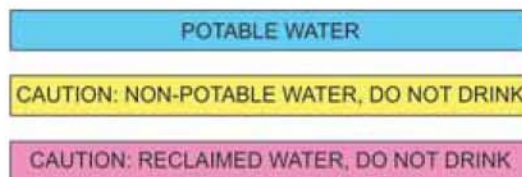

Figure 4.2.3: Identification Labels with Colour Coding

### 4.3 Quality of Water and Treatment

4.3.1 Quality of available water source should be established through a test report obtained from a recognized laboratory.

4.3.2 The extent of treatment shall be determined based on the quality of source water. This may include sand filtration to remove suspended solids, activated carbon filter to remove colour and odour, softening to remove hardness and disinfection (chlorination, ozonization, UV, etc.) to remove bacteria.

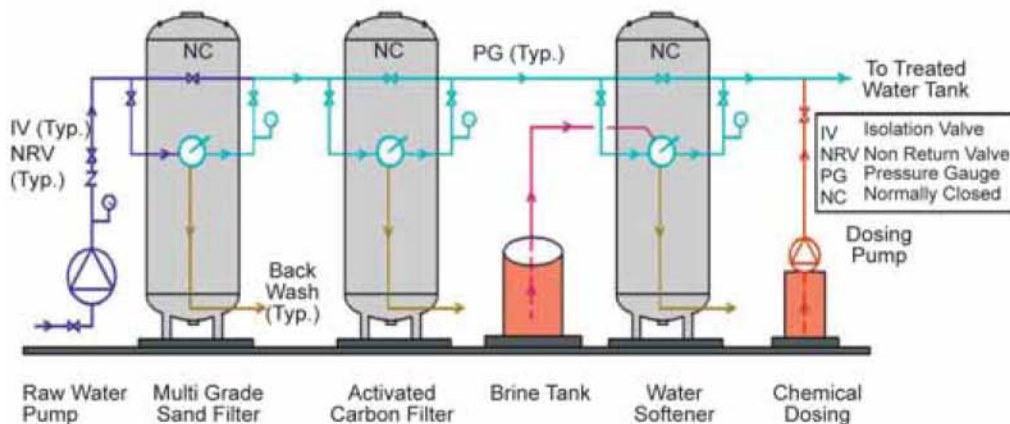

Figure 4.3.2: Schematic-Water Treatment Plant

4.3.3 Modern technologies are currently available to treat several impurities through single equipment. Expert advice shall always be sought on selection of appropriate technology/equipment.

4.3.4 Domestic water purifiers incorporating various technologies like cartridge filter, carbon filter, Ultra Violet (UV) treatment and Reverse Osmosis (RO) or combinations of the above are currently available. These are generally installed at the point of usage.

#### 4.4 Water Storage

4.4.1 Once the per capita consumption and the occupancy are established, the next step will be to determine the storage capacities. Water storage facility will be an essential component because the supply of water from government agencies/public utilities will usually be intermittent and often unreliable. On-site water sources such as open wells and bore wells, etc. if any, and their yields and quality shall also be determining factors.

4.4.2 It is currently a common practice to use alternative water sources for non-potable applications, in order to conserve the available potable water. This is a mandatory requirement for larger projects as per prevailing statutory regulations. Consequently, dual piping systems shall be required. Alternative water sources may include harvested rainwater, treated effluent from Sewage Treatment Plants (STP), untreated/partially treated well water, etc. which can be used for applications such as flushing of toilets and urinals, landscape irrigation, make-up water for HVAC equipment, etc.

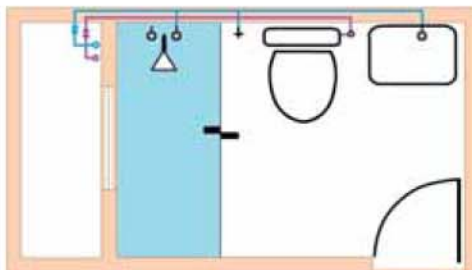

Figure 4.4.2: Dual Piping

4.4.3 Based on various sources and reliability of water available, storage compartments of adequate capacities shall be provided ensuring proper sanitary separation between compartments storing potable and non-potable water. Each type of water shall be provided with two compartments which can be independently used/isolated.

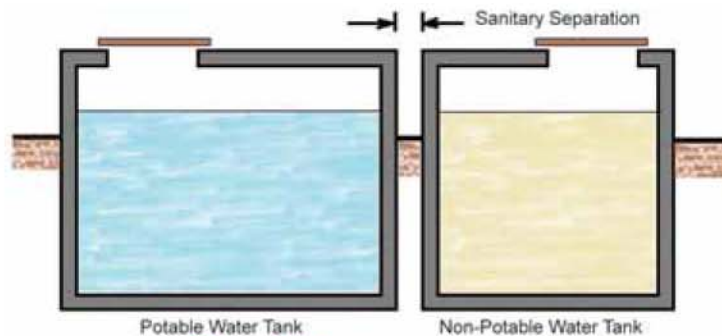
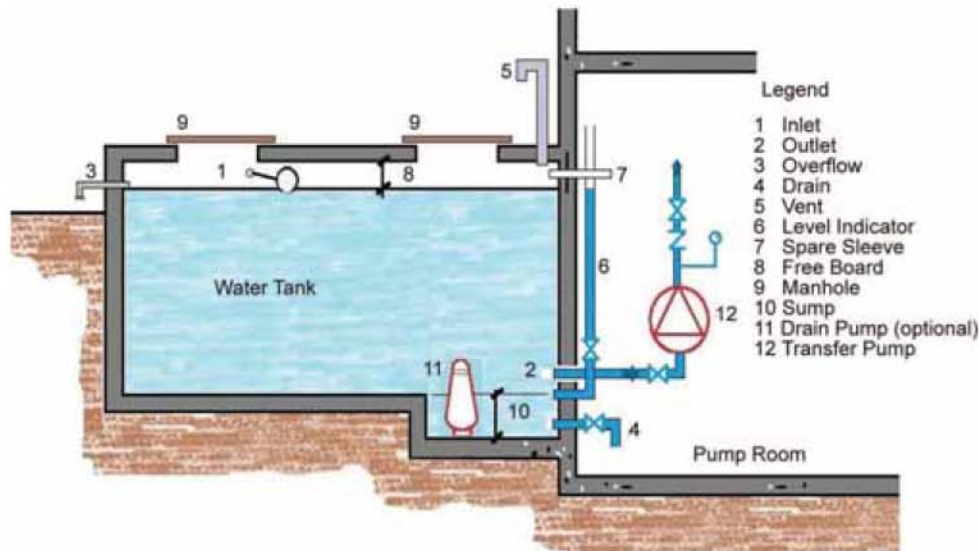

Figure 4.4.3: Sanitary Separation

4.4.4 Each tank compartment shall be provided with pipe work including inlet(s), outlet(s), drain, overflow and vent(s) (with insect screens), provisions for level indicator, level controller, etc. A free-board (vertical distance between soffit of the tank and top water level) of 200 to 300 mm shall be provided for installation of float valve, overflow pipe, etc.

4.4.5 Each tank compartment shall have manhole openings of appropriate sizes and numbers, sump(s) at the base for draining the tank. Additional sumps may be required in specific instances for installation of submersible pumps. Minimum size of the manhole opening shall be 560 mm dia or 600 × 600 mm. The numbers of manholes shall be dependent on the length of the compartment. A minimum of two manholes at diagonally opposite ends are recommended for safety reasons. Manhole covers shall be air tight and lockable where required. Selection of manhole covers shall also take into consideration the expected loading factors from regular traffic if any.



(Note: Drain pump is optional)

Figure 4.4.5: Water Tank Details

4.4.6 As far as possible water tank(s) shall be constructed to facilitate draining of the tank and overflow from tank by gravity. Manhole cover shall be adequately raised above surrounding ground level to prevent entry of surface water into the tank. Preferably, water tanks shall not be constructed under car parks, garages, etc. In unavoidable situations where water tanks are constructed below ground, suitably sized submersible pump(s) may be part of the permanent installation to facilitate draining/emptying of the tank.

4.4.7 Where possible water tanks shall be constructed with a common wall with pump room/plant room. The floor of the plant room shall be below the base of the water tank to facilitate flooded (positive) suction to pump. In such situations, draining of the tank, over flow from tank, monitoring of water level in the tank etc can be easily achieved.

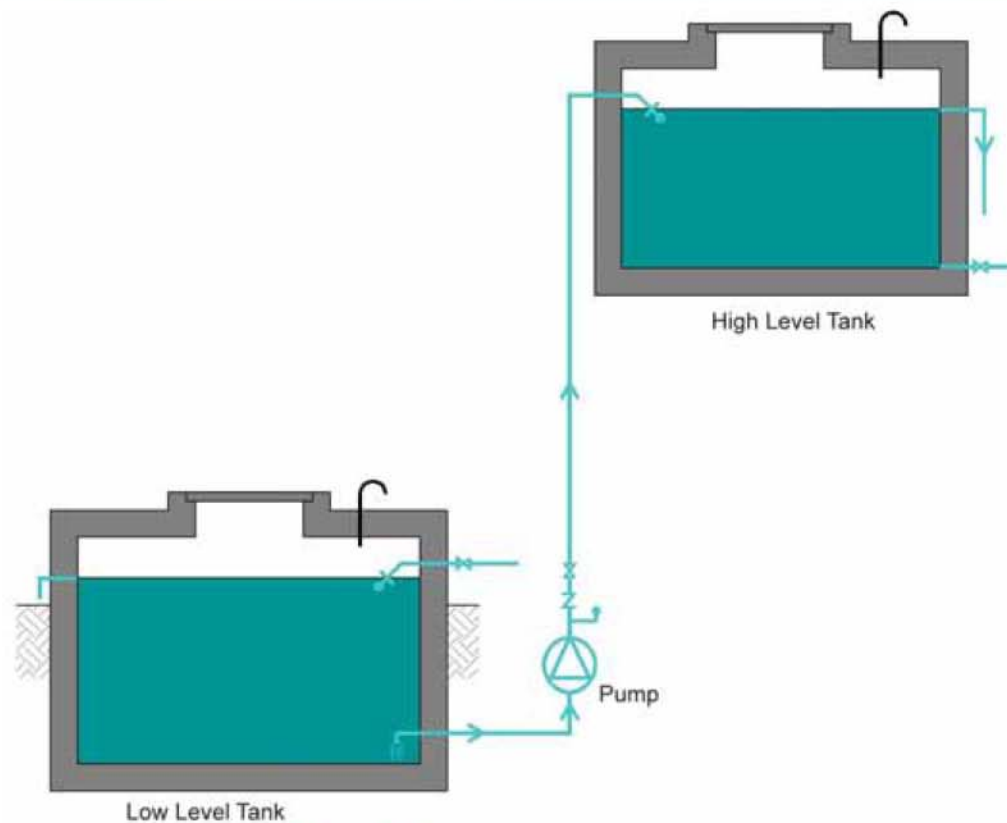

**Figure 3.4.7:** Low and High Level Tanks

4.4.8 Quantum of storage required shall be based on professional judgment in each instance. The general practice is to provide water requirement of one to two days in low level tank(s) and half to one day storage in high level tank(s) where gravity water distribution systems are considered. Where different sources of water with dual piping are provided for flushing and domestic applications, approximately one-third of the total storage shall be for flushing and the rest for domestic application. Considering modern equipment and technologies available, reduction of capacities in high level tanks can be considered to save structural cost of the building. Unless specifically called for, in water distribution systems dependent on hydro-pneumatic equipment (with standby power supply), a high level tank need not be considered. Level controllers can ensure automatic refilling of the high level tanks through setting the operation of transfer pumps.

#### 4.5 Water Distribution

4.5.1 Water distribution in buildings and premises can be achieved either by gravitational force from elevated storage tank(s) or by pumping equipment from low level storage tank(s) direct to the draw-off points. Plumbing codes prescribe a working pressure of minimum 0.5 bar (5 m water column). Where flush valves are used for water closets, the minimum pressure needs to be 1.0 bar (10 m water

column). Maximum working pressure stipulated by modern plumbing codes is 5.5 bar (55 m water column) although most practitioners prefer to restrict the maximum pressure to a lower level.

4.5.2 Water distribution system shall be installed such that they should be self-venting and self-draining. Dead ends, vertical loops, etc shall be avoided. Automatic air vents or such provisions shall be required at all high points and drain cocks shall be required at the lower points.

4.5.3 Water distribution system shall have provision to isolate pipe work in segments by providing adequate number of valves on branches serving group of fixtures and also at individual fixtures.

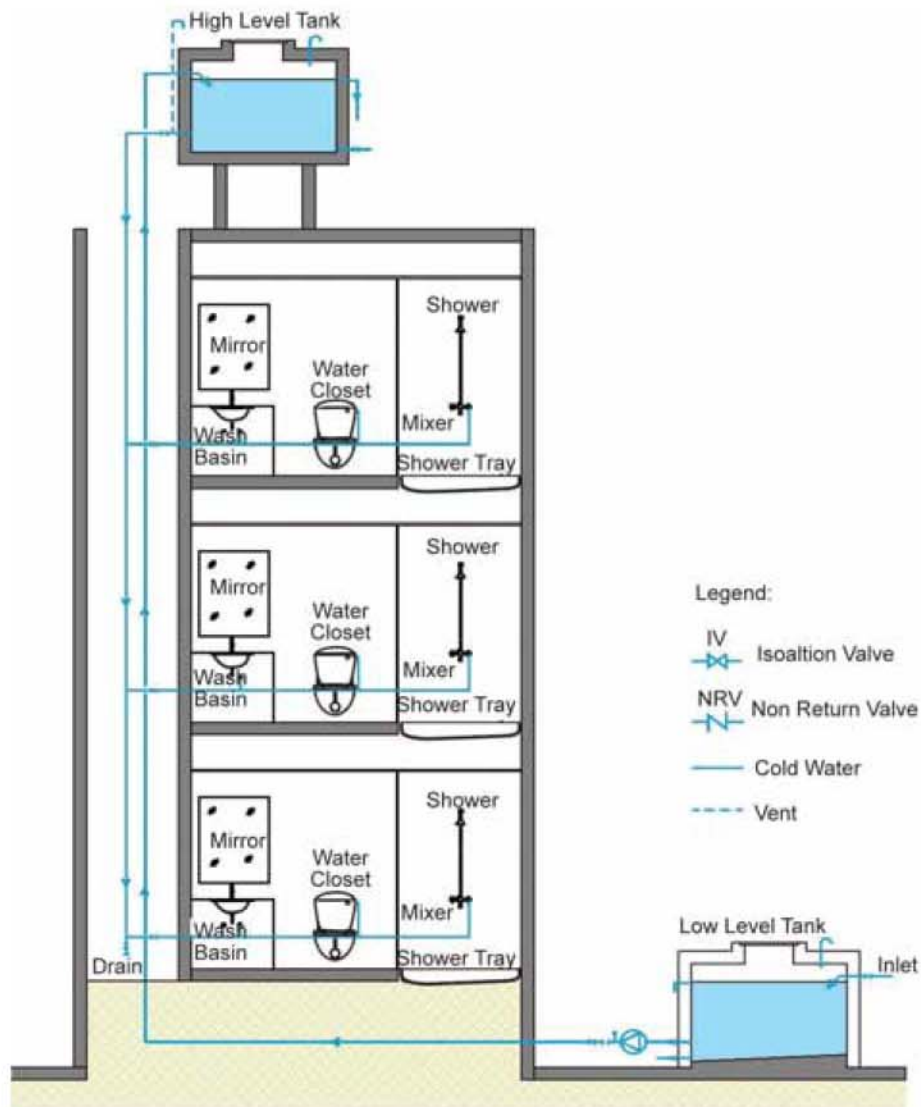

Figure 4.5.3: Water Supply-Gravity System

4.5.4 In high rise buildings exceeding, say 10 floors (floor height of 3–3.5 m), the distribution system will need to be divided into vertical pressure zones to ensure desired minimum and maximum residual pressures (the pressure at the draw off point).

4.5.5 In large complexes consisting of several buildings, a network of external water mains with facilities for isolation in segments may also be necessary.

4.5.6 In large network of pipes whether within individual buildings or for large complexes as described in (4.5.5) above, main supply pipes in ring formation will be advantageous to balance pressures at various locations, to reduce frictional losses and thereby achieve reduction of pipe sizes.

4.5.7 On distribution systems with the quick acting valves including flush valves, instances of water hammer and the resultant pressure surges will be frequent. Suitably sized engineered water hammer arrestors should be installed at appropriate locations.

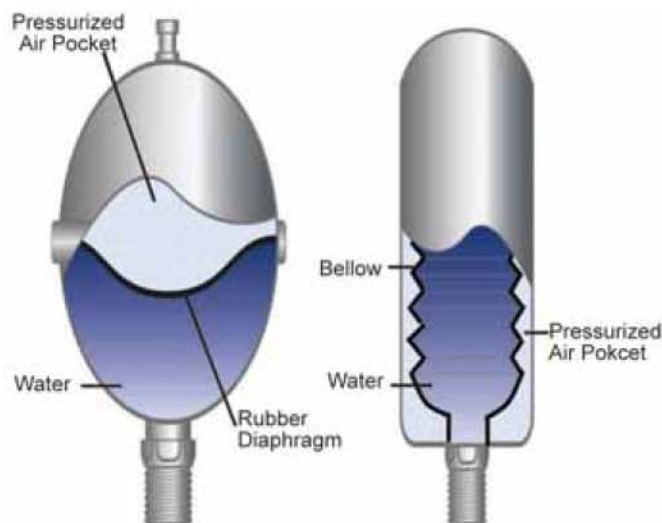

**Figure 4.5.7:** Water Hammer Arrestor

4.5.8 In instances where domestic water is supplied to water bodies, balancing tanks of swimming pools, cooling towers etc appropriate back flow preventers shall be provided to prevent back flow and consequent contamination of the domestic water system.

4.5.9 In determining pipe sizes, criteria to be considered are working pressure, velocity and flow rate.

4.5.10 Velocities in pipes should be restricted to 2.4 m/sec. However, when copper pipes are used for hot water distribution, the velocity should be restricted to 1.5 m/sec.

4.5.11 While selecting plastic pipes such as CPVC, uPVC, HDPE, PPR, PEX, PB, etc. provision shall be made for pressure de-rating at elevated temperatures. Pressure rating mentioned by manufacturers of most plastic pipes is at 23°C.

4.5.12 Provision shall be made in pipe work, especially plastic pipe works, for protection from expansion and contraction. Where proprietary expansion couplings, bellows etc are unavailable, suitably designed expansion loops shall be considered. Expansion devices shall be provided on pipe work where they cross building expansion joints.

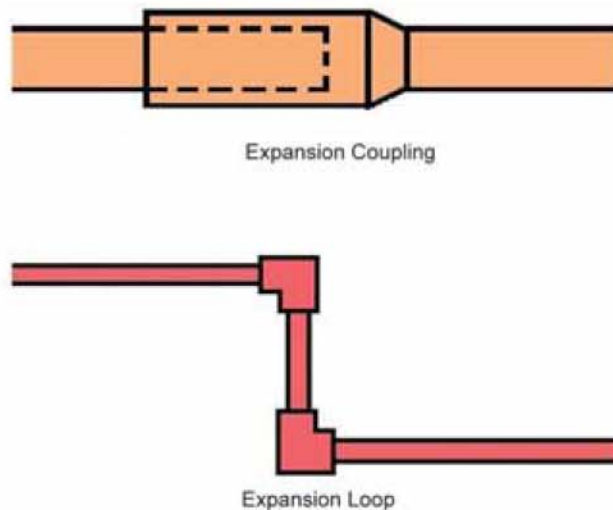

**Figure 4.5.12:** Expansion Coupling and Loop

4.5.13 Flow rates in pipes shall be decided based on the flow requirements of various fixtures in the system. The codes have assigned Water Supply Fixture Unit values (WSFU) for various fixtures and appliances normally used in the system. Total fixture unit values will be the cumulative value of all fixture units served by a particular pipe. Flow rates corresponding to fixture units can be determined from the charts available in the Code.

4.5.14 As far as possible, pipe work shall be installed in plumbing shafts, ceiling voids etc minimizing burying of pipes within structural elements.

4.5.15 Appurtenances serving multiple user points shall be installed in common areas facilitating easy access for repairs and maintenance. This will include large pressure reducing valves, centralized thermostatic mixing valves, common water meters serving number of tenements, etc.



**Figure 4.5.15:** Pressure Reducing Valve (PRV)

4.5.16 Support spacing for various types and sizes of pipe work shall be based on provisions in the plumbing codes and also recommendations of manufacturers. Closer supports will be required for horizontal runs compared to vertical runs. Spacing of supports shall increase as the pipe diameter increases as shown in the figure below:

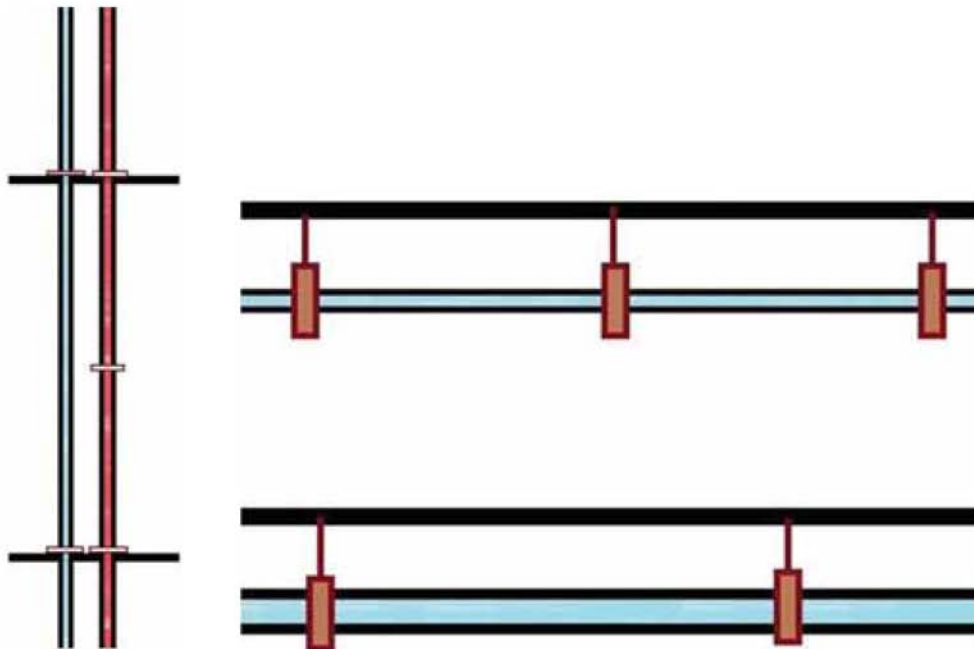

*Figure 4.5.16: Hangers and Supports*

4.5.17 Pipes shall be installed away from structural/building elements such as walls, ceilings, etc. keeping a clear space of minimum 40 to 50 mm.



*Figure 4.5.17: Clear Space from Wall*

4.5.18 Plastic pipe works shall not be constantly exposed to ultra violet rays unless adequate external protection is provided by means of insulation, protective coating, etc.

4.5.19 Water distribution systems shall be subjected to hydraulic tests of minimum 1.5 times the specified working pressure. The system shall retain the test pressure for a minimum of 30 minutes and drop in pressure if any shall be within permissible limit. The system shall be flushed and disinfected prior to being put to use.



Commonly used method of disinfection is by using chlorine solution of 50 parts per million (50 grams of concentrated chlorine for 1000 liters of water). The system shall be charged with water and the solution shall be added and retained for a minimum of 24 hours. Thereafter, the pipes shall be flushed with clean water. The procedure shall be repeated as required until water collected at the lowest point at the farthest end shall have distinct smell of chlorine.



*Figure 4.5.19: Hydraulic Pressure Test Pump*

4.5.20 Where dual piping systems are installed for domestic and flushing water, pipes of different colour/appearance shall be used to prevent accidental cross connections during installation or maintenance. Additional protection shall be given by colour coding and identification labels as recommended by plumbing codes.

#### 4.6 Hot Water Generation and Distribution

4.6.1 Depending on the nature of occupancy and quantum of hot water required, one of the following methods or a combination may be adopted for hot water generation:

- Instantaneous electric water heaters
- Storage type electric water heaters (low pressure and high pressure)
- Gas fired instantaneous water heaters
- Gas fired storage water heaters
- Diesel/Furnace oil fired water heaters

- Solar hot water systems
- Heat pumps

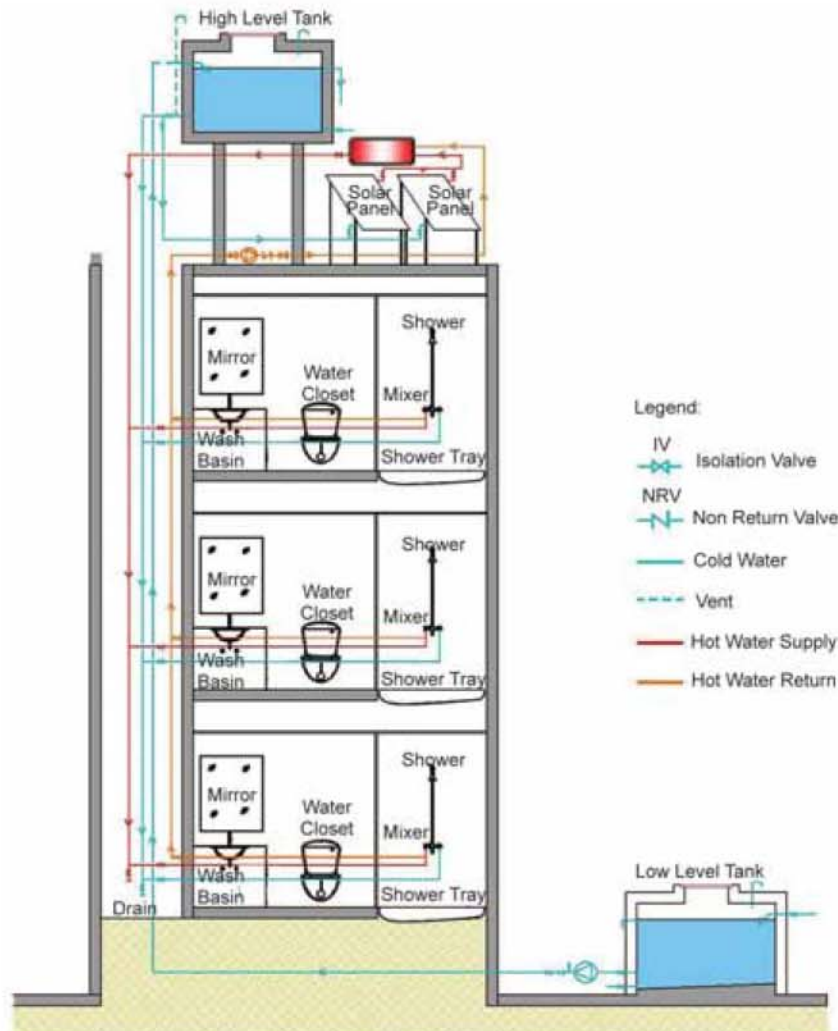

**Figure 4.6.1:** Hot Water Supply System

4.6.2 Current statutory regulations in many parts of the country mandate usage of non-conventional energy sources like solar energy to meet part of the hot water generation.

4.6.3 Hot water distribution system shall generally be similar to domestic cold water distribution system except that recirculation pipe work shall be added for instant availability of hot water and conservation of energy. The system shall include pipe work, isolation valves, automatic air vents, drain cocks etc as described for cold water system. Additionally, supply and recirculation pipes will require thermal insulation to prevent loss of heat. Pipe work at large centralized hot water generator(s) will also require specialized equipment such as expansion vessels.

4.6.4 Large centralized hot water systems will also comprise of ancillaries such as heat exchangers, mixing tank, manifolds, circulating pumps, valves, strainers and necessary instrumentation. They can also be integrated with heat recovery available from air conditioning and other systems to conserve energy.

#### 4.7 Safety Measures in Water Distribution

4.7.1 An incorrectly installed water distribution system can have serious implications on health and safety of the users. Preventive measures to be adopted shall include the points described below.

4.7.2 Minimum qualities of water prescribed earlier in this chapter shall be ensured especially in potable water so as to prevent water borne diseases. Most known communicable diseases are caused by inadequate quality of potable water apart from unsafe sanitation.

4.7.3 Prevention of backflow and back siphonage is of extreme importance. Back flow could occur by accidental or unintended cross connections between potable and non-potable water distribution pipes causing contamination of the former. Precautionary measures as described in the plumbing codes must be strictly adopted. One of the simple measures of preventing back siphonage is the provision of an atmospheric air gap of minimum 25 mm between the tip of the faucet and the overflow level of the fixture such as a sink.

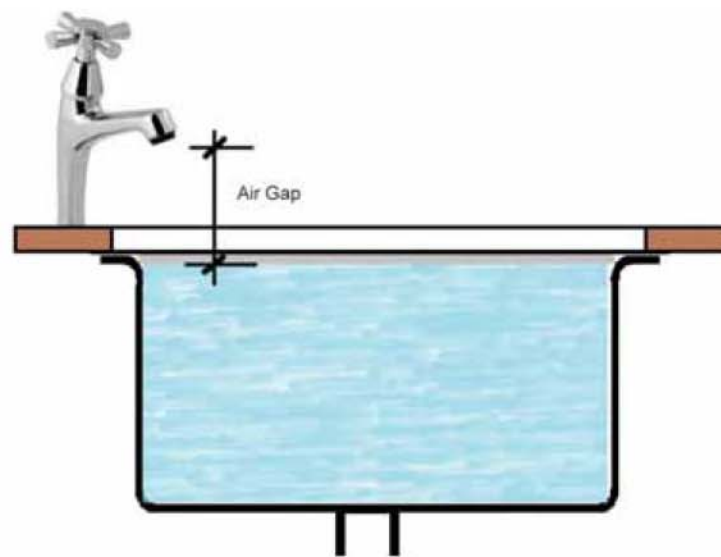

*Figure 4.7.3: Air Gap*

4.7.4 Scalding occurs due to excessive temperature of hot water at the user points often caused by pressure imbalances at mixers between hot and cold water supplies, especially at showers. Pressure imbalance also causes thermal shocks when flow of either hot or cold water suddenly decreases. Modern plumbing codes stipulate temperature and pressure (T&P) balancing mixing valves to prevent such accidents.

Thermostatic mixers commonly available and used at user points such as shower mixers are only temperature balancing units which prevent scalding, but not thermal shocks. Centralised thermostatic mixing valves can also be used for a number of user points instead of individual valves at each location.

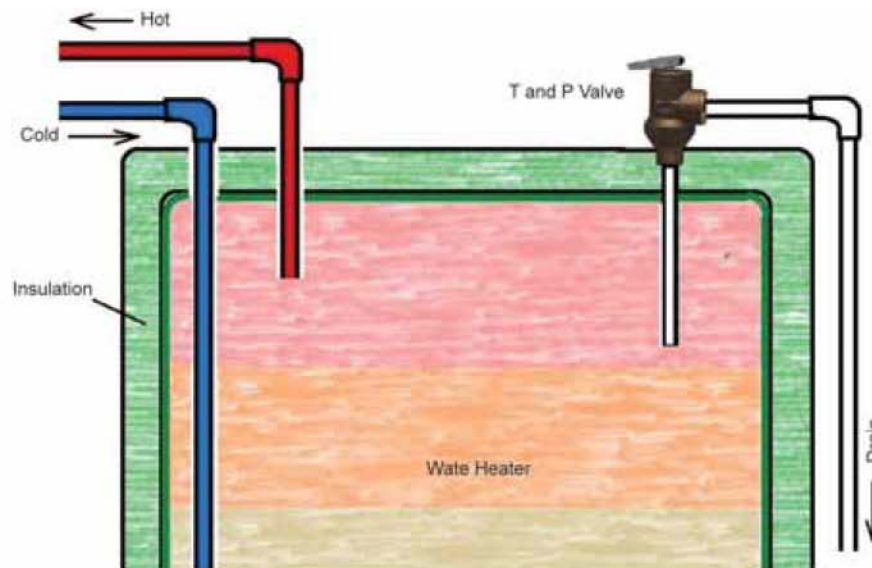

*Figure 4.7.4: T&P Valve*

4.7.5 Additional care shall be exercised on solar hot water systems where the temperatures can rise well above scalding temperature. In cases where mixing tank is not provided, a centralised thermostatic mixing valve as described above shall be installed at the hot water outlet leading to the user point. Additionally, metallic pipe work shall be used for a minimum of 2 m from hot water outlets in the immediate vicinity of solar panels.

4.7.6 Incorrect setting of hot water temperatures in centralised systems can also cause serious consequences such as growth of dangerous legionella bacteria. Temperatures in the range of 25°C to 51°C assist the growth of the bacteria. A delicate balance needs to be achieved by preventing excessive temperatures which cause scalding and low temperatures which help growth of legionella.



# Soil and Waste Drainage

## 5.1 General

5.1.1 The terminologies of 'soil' and 'waste' commonly adopted in India can be described as follows:

- *Soil pipe*: pipe carrying waste water from water closets, urinals and bidets, also called black water.
- *Waste pipe*: pipe carrying waste water from all other sanitary fixtures and appliances except as mentioned above, including showers, bathtubs, wash basins, kitchen sinks, cloth washers and dish washers, also called grey water.

## 5.2 Types of Installations

5.2.1 Methods adopted for building drainage systems can broadly be categorized into three types.

- Two pipe systems with separate soil and waste pipes and additional ventilating pipes for cross venting of soil and waste stacks (cross venting of stacks in buildings three floors or more). Refer Figure 3.1.3b.

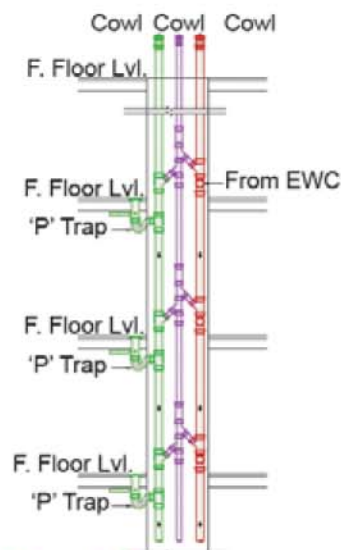

Figure 5.2.1a: Two Pipe System

The drainage system commonly used in India for several years, although proven safe, is at variance with advanced technologies currently in vogue, especially in plumbing installations of the developed world. The system adopted in India has considerations for inadequacies that existed in the Indian plumbing industry especially in terms of availability of technically correct products (such as floor traps and fixture traps with required depth of water seal) and availability of skilled work force in required numbers. With the trend of large, complex and high rise buildings in the past decade or so, the system adopted calls for review especially as availability of technically correct products in domestic market has improved largely.

Another reason for adaptation of the system described above is the mandatory requirement of floor drain(s) in wash rooms, kitchens and utilities.

Every plumbing fixture connected to a waste stack is trapped thrice- at the fixture, waste pipe from fixture connected to the floor drain and the waste pipe stack connected to a third trap prior to discharge into the building drain. Inadequacies in water depth of the three traps and possible loss of water seal are compensated by frequent replenishment of water seal each time a fixture is in use.

Except in certain parts of India, the segregation of pipework for soil and waste is limited only to within the building structure. The building drain will be a common pipe leading to the public sewer or on-site treatment plant.

The major disadvantage of the system especially in high rise buildings is that they are uneconomical since three pipe stacks are installed instead of two as in (b) and one in (c). Additionally, the space requirement for installation of pipes in plumbing shafts, plenums, ceiling voids, etc. will be larger.

Current construction methods adopted in India will require modifications to accept alternative drainage systems as described further under (b) and (c).

- b. A fully ventilated one pipe system where suitably sized pipe stacks carry soil and waste drainage as described in UIPC-I wherein each sanitary fixture is individually vented.

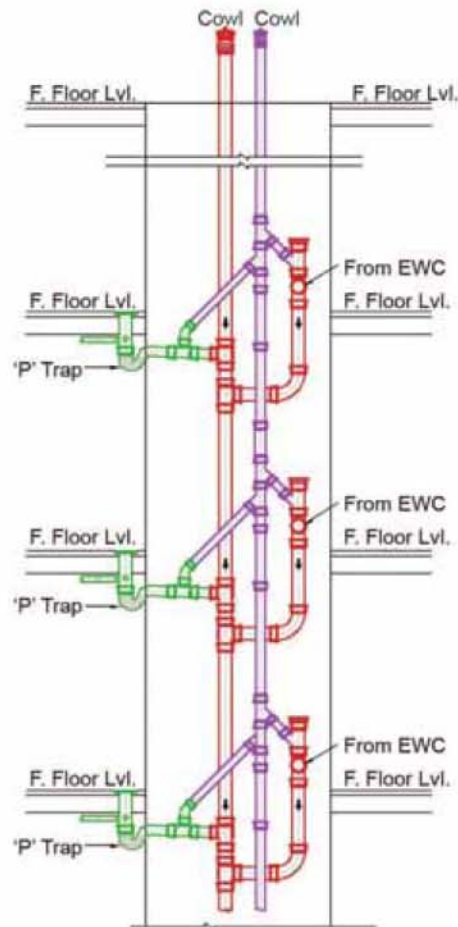

*Figure 5.2.1b: One Pipe System*

The system described here calls for venting of individual sanitary fixture, but the design and construction methodology adopted in India often do not permit such installation. RCC lintels, beams, etc. normally obstruct vertical vent pipes leading to the ceiling void and thereafter to the nearest plumbing shaft where vertical ventilating stacks are installed. Additionally, with the requirements of floor drains in washrooms, kitchens, utilities, etc. plumbing fixtures are usually connected to the nearest floor drain. A practical way of implementing this system in the construction projects in India will be by venting each water closet and floor drain.

Horizontal drainage pipes in the current systems are laid either in the sunken floor or suspended below the floor. Venting the floor drain in the former will be difficult if not impossible. UIPC-I describes how ventilating pipes are to be installed on suspended drainage pipes as described here.



- A fully vented one pipe drainage system as described in this section is the most popular in advanced plumbing installations. However, the construction methods adopted in these installations provide adequate space by way of adjoining plumbing shafts, voids created by dry wall construction, etc. where the ventilating pipes from individual fixtures can be easily installed. Inadequacies in most fixture traps and floor traps manufactured in India create limitations in implementation of such an advanced installation. Special care shall be taken to ensure that the traps used are of self-cleansing design and have minimum water seal of 50 mm as stipulated by UIPC-I. If these fundamental requirements are carefully addressed and the workforce adequately trained, implementation of such systems can result in substantial cost savings.
- c. Single stack system commonly adopted in European countries (also described in UIPC-I) where suitably sized pipe stacks carry soil and waste drainage with minimal venting requirements. In such cases, stacks shall be of a larger size to provide adequate central air core as separate vent pipes are avoided.

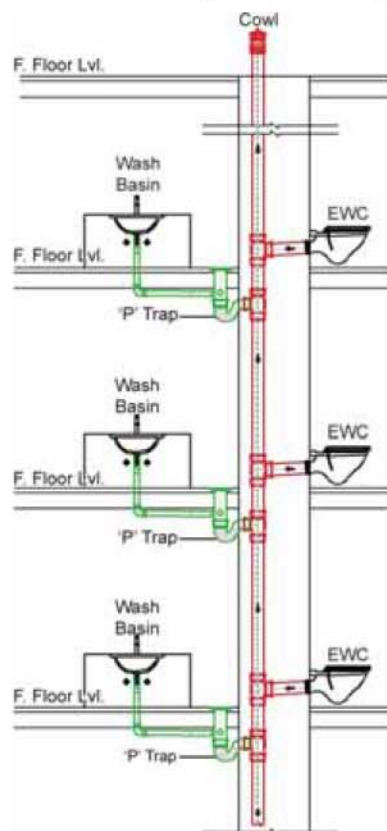

**Figure 5.2.1c:** Single Stack System

The flow of liquid in a vertical drainage stack is restricted to one-third of its carrying capacity with the central core for movement of air. A single stack system tries to avoid or minimize requirement of ventilating pipes by sizing the drainage stack adequately for carriage of liquid and movement of air. Due to this, the pipe stacks are often of a larger diameter compared to the system described in (b).

Single stack systems have other restrictions including length of branch soil and waste pipes connected to the drainage stacks and minimum distance requirements between connections onto the stack. Various manufacturers have proprietary products to receive multiple staggered branch connections onto the stack. The purpose of proprietary products described here is for the branch soil and waste pipes to discharge into the stack without disruption to the central air core in the stack.

A single stack system is probably the most economical of the three described here provided adequate planning is undertaken at the design stage of the building with washrooms located around plumbing shafts, minimizing length of branch soil and waste pipe.

### 5.3 Sizing of Pipes for Drainage

5.3.1 As described earlier in this chapter, drainage pipe stacks are sized for one-third of their carrying capacity.

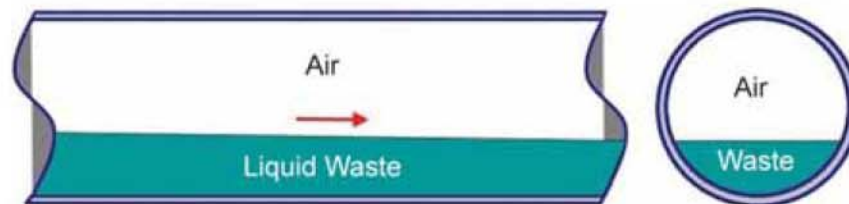

Figure 5.3.1: Horizontal Drainage Pipe

5.3.2 Plumbing codes provide values of drainage fixture units (DFU) for each fixture. Different values of DFUs are assigned for fixtures also based on the nature of occupancy where they are installed. UIPC-I categorizes them as Private, Public and Assembly. Although the fixture used may be the same, their DFU values vary based on frequency of usage. For example, DFU value for a water closet with cistern in a private, public and assembly occupancies are 3, 4 and 6 respectively.

5.3.3 Sizing of drainage pipes is based on the cumulative value of DFUs of all the fixtures connected to that pipe. A vertical pipe shall always have a larger carrying capacity when compared to a horizontal pipe of the same size. This is due to flow patterns in the two instances. Carrying capacity of a horizontal drain pipe shall also be dependent on the gradient provided. For example, UIPC-I stipulates a total carrying capacity of 216 DFUs for a 100 mm horizontal pipe with a gradient of 1: 50 (2%) whereas the same pipe with a gradient of 1:100 (1%) can only carry 172 DFUs (80%). Carrying capacities of vertical drainage pipes are also restricted by their maximum permissible lengths. For example, the carrying capacity of 256 DFUs of a 100 mm vertical drainage pipe is also subject to a maximum length of 91m. This restriction on length does not apply to horizontal drainage pipes.

5.3.4 Plumbing codes also stipulate minimum size of outlet pipe from each plumbing fixture in addition to the DFU value assigned. Irrespective of the DFU value assigned, the minimum pipe size for the fixture is to be adhered to.

5.3.5 While there are no minimum cumulative DFU value stipulated for horizontal pipes within buildings, carrying capacities of building sewers (external sewers-200 mm  $\Phi$  and larger) are expressed in minimum and maximum values. The minimum values are critical to ensure self-cleansing velocities in sewers.

5.3.6 Gradients for horizontal drainage pipes are determined based on their diameters. Usage of a larger pipe than dictated by the cumulative DFU values in order to reduce the gradient is not recommended since this could affect self-cleansing velocities resulting in what is termed as 'dry drains'.

#### 5.4 Traps

5.4.1 Water closets and in some cases urinals are provided with integral traps. All other fixtures shall be provided with external traps with adequate water seal. Diameter of the trap shall in no case be smaller than the diameter of the outlet of the fixture to which it is connected. Traps shall be of self-cleansing design with uniform bore and shall not be dependent on internal partitions or other movable parts for retention of water seal. Connection of a trap into another trap should not be practiced. Diameter of outlet pipe from a floor trap shall not be less than size of the trap outlet. For additional information, refer Section 2.24.

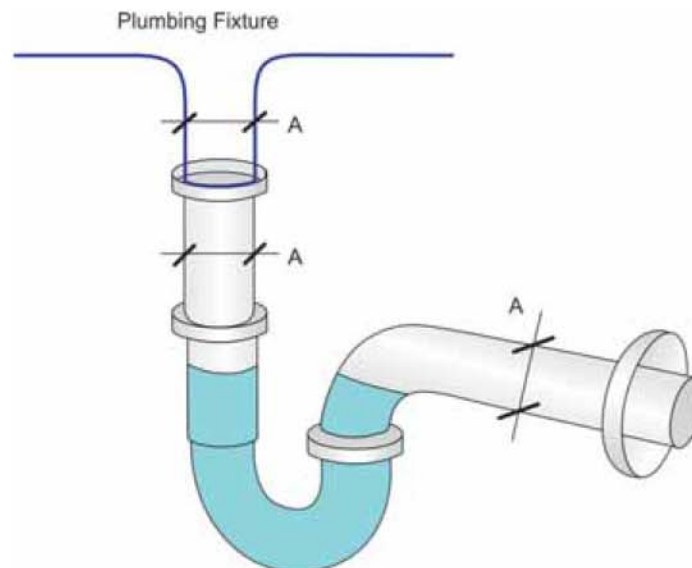

(Note: A indicates diameter)

**Figure 5.4.1:** Fixture Trap

#### 5.5 Vents

5.5.1 Properly sized and installed vent pipes ensure maintenance of atmospheric pressure within gravity drainage pipes and are integral parts of drainage installation. Occurrence of positive or negative pressures within the drainage system causes siphonage and blow off of trap seal resulting in entry of dangerous sewer gases into living premises.

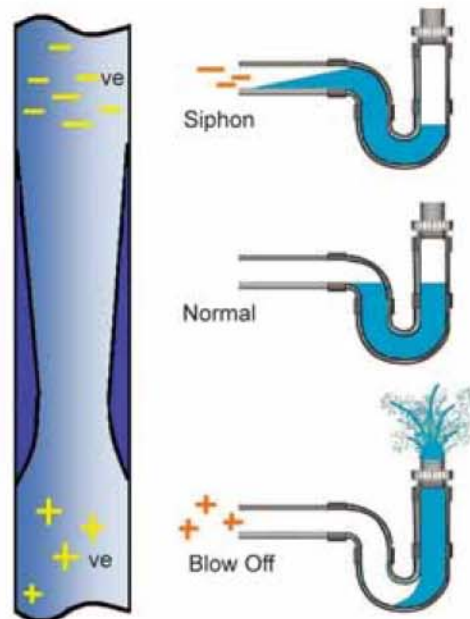

*Figure 5.5.1: Siphonage and Blow-Off of Trap Seal*

5.5.2 Sizing of a vent pipe is based on cumulative DFUs of all fixtures served by that pipe. In addition to the DFU values, sizing of vent pipes is also dependent on maximum permissible lengths. Maximum lengths of vent pipes of specific sizes permitted in UIPC-I are also subject to the limitation that no more than one-third of the length shall be horizontal. For example, maximum permitted length of a 100mm vent pipe is 91 m. However, not more than 30 m of this pipe run should be horizontal and the rest shall be vertical. Horizontal vent pipes shall always rise constantly towards the termination point, avoiding vertical loops.

5.5.3 In specific cases where natural vent pipes as described in 5.5.2 cannot be installed, a combination of air admittance valves (AAV) and positive air pressure attenuators (PAPA) are considered to be an alternative. However, due to their limited availability and high costs, a natural vent pipe is commonly adopted. Experience reveals that installation of at least a minimum number of natural vent pipes will be preferable on installations with AAV and PAPA.

5.5.4 In addition to gravity drainage systems as described above, ventilating pipes are also to be installed on sanitary fixtures/installations such as grease interceptors, septic tanks, sewage sumps and pump stations.

## 5.6 Inspection Chambers and Manholes

5.6.1 Except in instances where sealed drainage systems with rodding eyes/cleaning points are opted for, inspection chambers/manholes are to be provided on gravity drainage systems for the purpose of cleaning and maintenance. As the term suggests, an inspection chamber is one where the desired purpose can be accomplished without entering the drainage system. Manhole is a term often used for a larger chamber with adequately sized opening for an operative to enter into deeper sewers.

5.6.2 Inspection chambers/manholes are to be provided on gravity sewers at regular intervals, at changes of direction, at locations of branch connections, at major changes in invert levels of inlet and outlet pipes and at changes of diameters of inlet and outlet pipes. In building drainage systems, where inspection chambers/manholes are provided on straight sewers at regular intervals, the distance between the two shall not exceed 30 m.

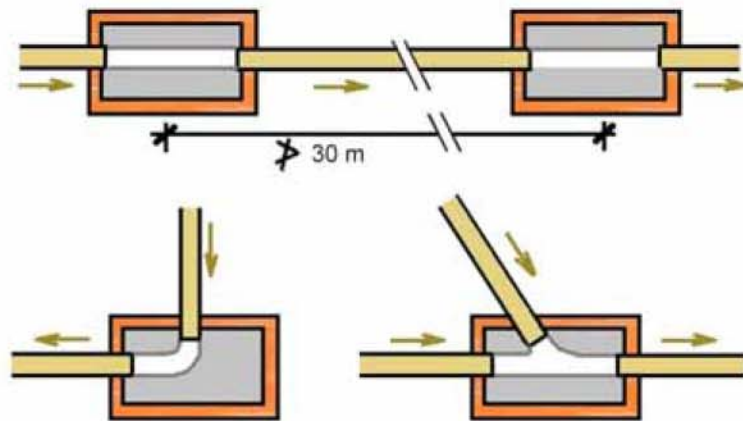

Figure 5.6.2: Inspection Chambers

5.6.3 Crown of inlet or branch pipes in an inspection chamber/manhole shall not be lower than the crown of the outlet pipe.

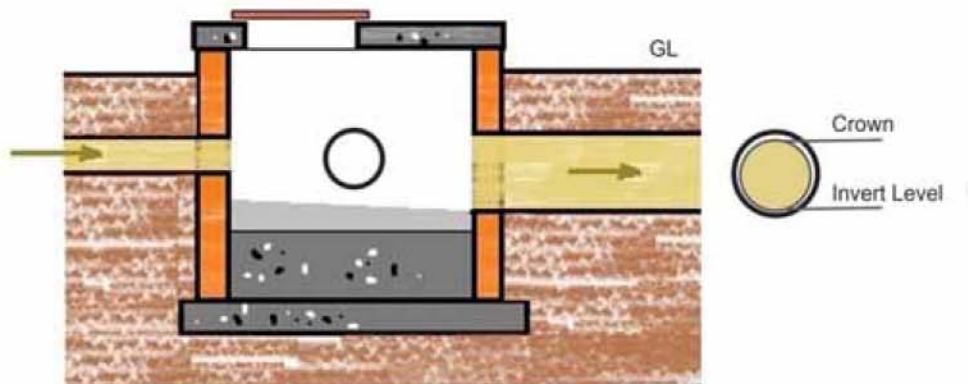

Figure 5.6.3: Crown and Invert Level

5.6.4 Branch entries to inspection chambers/manholes shall not be at angles less than  $90^\circ$  to the outlet pipe/direction of flow.

5.6.5 Branch entries shall not be installed one directly above the other. All branch entries shall be connected to the main channel with sweep branch channels.

5.6.6 Benching between branch channels shall not be less than 150 mm wide.

5.6.7 Depth of main channel shall not be less than two-third diameter of the outlet pipe.

5.6.8 Benching on the floor of inspection chambers/manholes towards the main channel shall be at a slope of minimum 1:10.

5.6.9 Drop connections shall be provided at inspection chambers/manholes where the difference in invert levels of inlet/branch and outlet pipes exceeds 600 mm.

5.6.10 Foot rests/rungs shall be provided on inspection chambers/manholes deeper than 600 mm.

5.6.11 Covers of inspection chambers/manholes shall withstand the loads caused by the traffic over it.

5.6.12 Inspection chambers/manholes shall be avoided within building premises. Where unavoidable, the covers shall be air tight.

5.6.13 Structural details of inspection chambers/manholes including base concrete, walls, internal and external plaster etc shall be determined based on surrounding ground conditions, depths of the structures and the traffic over it.

## 5.7 Gravity Drains and Pumped Sewers

5.7.1 As far as possible gravity drainage systems should be opted for. However, various factors such as washrooms/kitchens/pantries at floors below grade, site contours, extensive length of drainage systems causing deep drains etc may call for installation of pumped sewage systems.

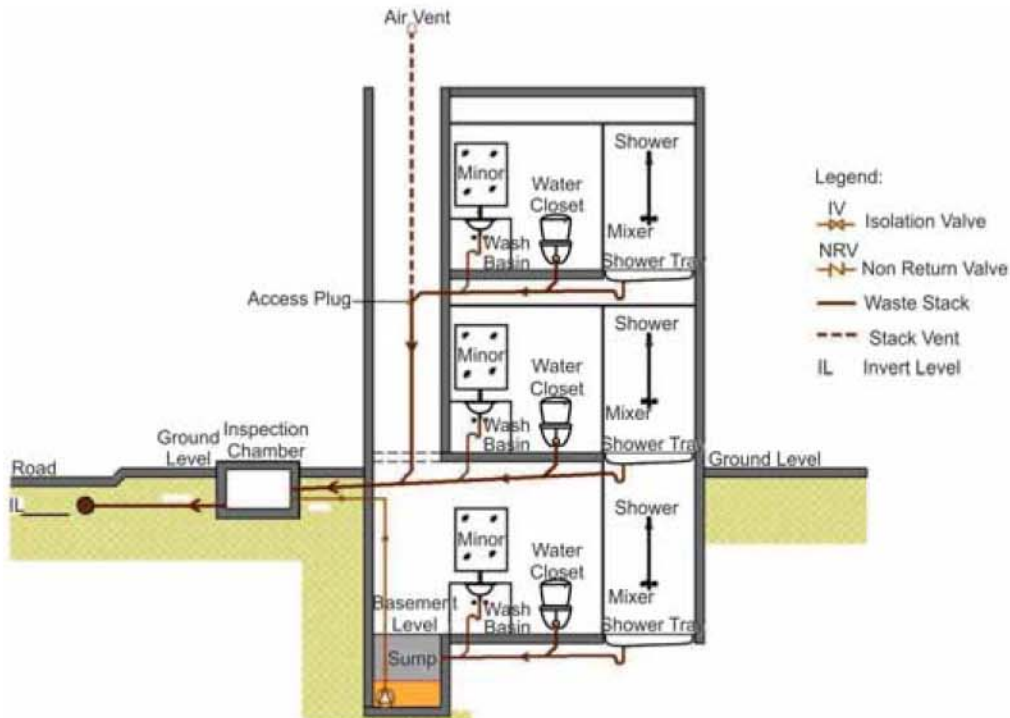

(Note: Sewage sump to be vented adequately)

Figure 5.7.1: Pumped Sewage System

5.7.2 Various sections of this publication have dealt with gravity drains and components extensively. Adequate venting shall also be provided to gravity drains.

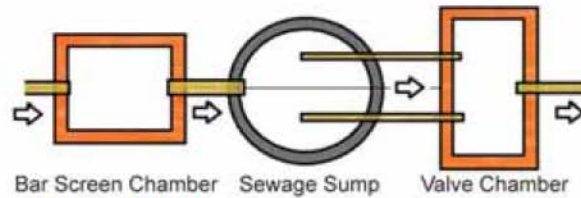

**Figure 5.7.2:** Schematic-Sewage Pump Station

5.7.3 Pumped sewage systems shall consist of a sewage sump with duty and standby pumps, a screen chamber preceding it, a valve chamber after the sump and a sewage rising main up to the discharge point.

5.7.4 Sewage sumps can be constructed of masonry or RCC as required depending on site conditions. Circular sumps are preferred in order to avoid corners where sludge could get collected. Capacities of sewage sumps should be calculated based on the diameter of the sump and the depth below the incoming gravity sewer. Incoming sewage flow to the sump can be calculated based on cumulative fixture units of all plumbing fixtures connected. Volume of sewage to be retained in the sump at any given time shall be determined based on the flow rate and the number of permitted starts and stops of sewage pumps. A storage volume for pumping of ten minutes is usually considered adequate. Opening and cover over the sump shall be large enough for withdrawal of pumps without entering the sump.

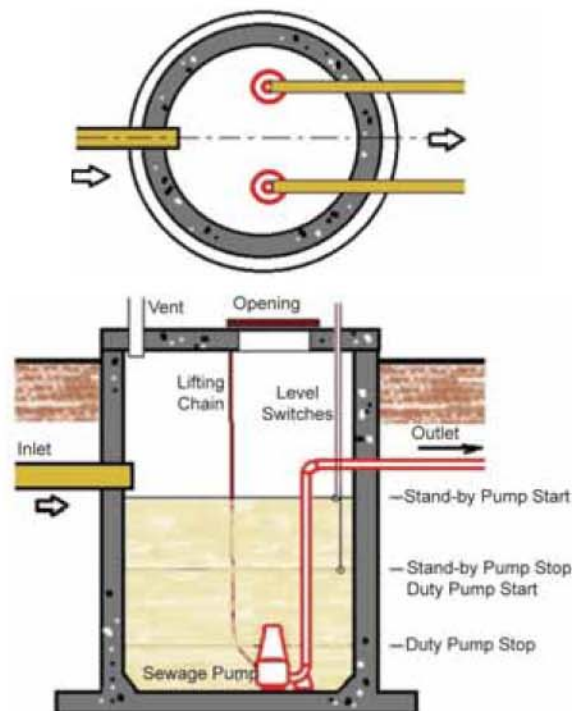

**Figure 5.7.4:** Sewage Collection Sump

5.7.5 Sewage pumps are generally of high discharge, low head with reduced speed (generally 1450 RPM). Once started, sewage pumps shall continuously run for 2 to 4 minutes minimum as recommended by manufacturers. Each sewage pump shall be sized for 100% capacity of the incoming flow. Pumps shall be installed to operate in a duty/assist/standby configuration using level controls in sewage sumps. Sewage pumps shall have an impeller passage of minimum 50mm. Operation of sewage pumps shall alternate between cycles to ensure even wear and tear of pumps. Large pumps shall be installed with duck foot bends, guide rails and lifting devices.

5.7.6 The screen chamber preceding the sewage sump shall be a suitably sized masonry/concrete chamber with a bar screen for manual raking and removal of large particles thereby preventing their entry to the sewage sumps.

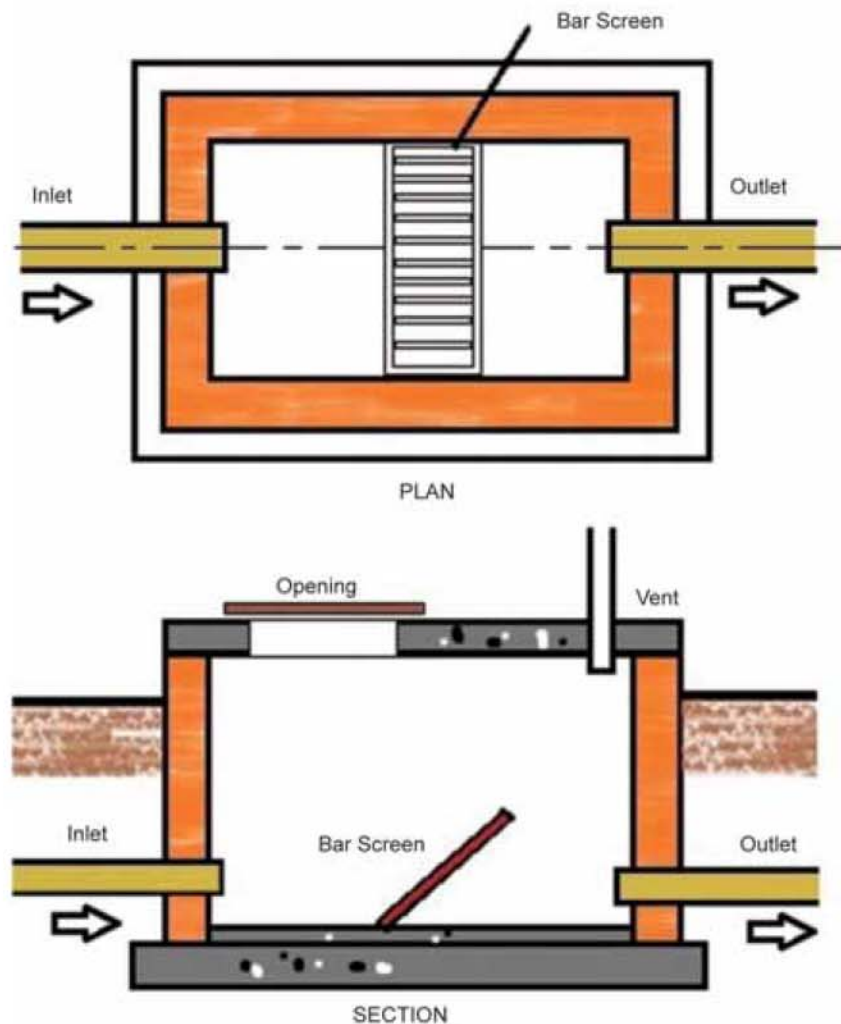

Figure 5.7.6: Bar Screen Chamber



5.7.7 A valve chamber constructed after the sewage sump shall include a pipe manifold with non- return valves and isolating valves. The manifold shall also include a drain connection with an isolating valve to periodically flush the rising main back to the sewage sump.

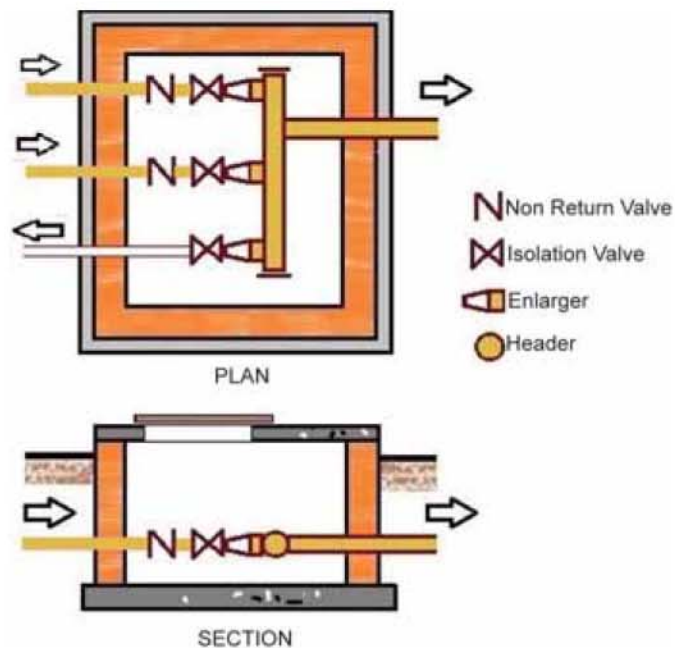

Figure 5.7.7: Valve Chamber

5.7.8 Size of the rising main shall be determined based on the combined flow when both sewage pumps are in operation in duty and assist mode. Velocities in sewage rising mains shall be restricted to 1.5 m/s.

## 5.8 Sewage Treatment Systems

5.8.1 Due to non-existence of public sewer systems in most locations and also to comply with statutory regulations, property owners are required to make provision for on-site sewage treatment facilities.

5.8.2 Small buildings such as individual homes can be catered to by a combination of well-designed septic tank and soak pit/up-flow filter/dispersion trenches with perforated pipes.

5.8.3 Large buildings will require engineered sewage treatment plants (STP) with tertiary treatment facilities enabling use of recycled/reclaimed effluent for non-potable applications such as flushing, landscape irrigation and make-up water for air conditioning requirement.

# Rainwater Drainage and Harvesting

## 6.1 Rainfall Intensity

**6.1.1** The primary requirement to design rainwater drainage/harvesting system is reasonably accurate knowledge of rainfall intensity at the location of the project. In a vast country like India, rainfall intensity varies substantially at different locations, ranging from 300 to 3000 mm per annum. There are small pockets of the country like Chirapunji in the state of Meghalaya and Agumbe in the state of Karnataka where total annual rainfall recorded has exceeded. Additional information on rainfall at various parts of the country are regularly published by the Indian Meteorological Department (IMD).

**6.1.2** While designing rainwater drainage systems, including sizing of roof outlets, pipes, and gutters etc the maximum rainfall intensity experienced/expected in the region is to be considered. These are expressed as mm/hr. For example, plumbing engineers generally consider an intensity of 75 mm/hr while designing rainwater systems in the city of Bengaluru. It needs to be understood that this method is adopted to cater to even cloud bursts wherein the high intensity rains might last only for a few minutes.



**Figure 6.1.2:** Rainwater Gauge

## 6.2 Drainage system

6.2.1 Catchment areas for rainwater harvesting/disposal systems can broadly be categorized as follows:

- Built roofs from where the collected rainwater can be reused
- Other areas such as paved areas around buildings, landscaped areas, roads, parking lots, balconies, podiums etc from where rainwater can be collected and recharged into the subsoil or disposed off to the external drainage systems.

6.2.2 Rainwater drainage systems for disposal/recharge shall include sand interceptors. These are constructed as separate units at the final discharge point, in addition to provisions made in catch basins/inspection chambers in the piping system.

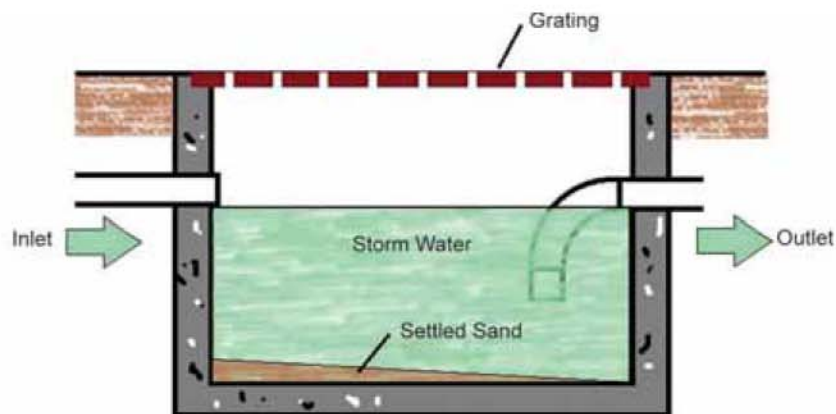

(Note: In large diameter storm drains the bend at the outlet may be replaced with a baffle wall)

**Figure 6.2.2:** Sand Interceptor

6.2.3 In cases such as storm drainage from parking lots, petrol pumps, etc. pre-treatment using oil interceptors may have to be installed prior to disposal of storm water into the external drain.

6.2.4 Sizing of rainwater downpipes is usually done considering partial flow in the pipe whereas horizontal pipe runs are sized assuming full flows.

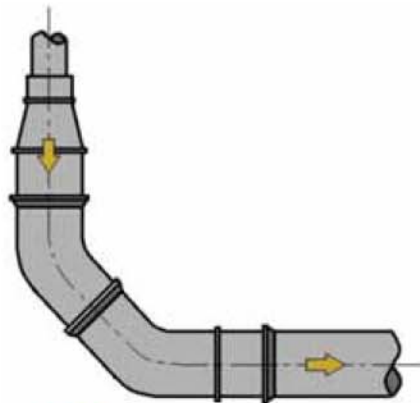

**Figure 6.2.4:** Vertical to Horizontal Connection

**6.2.5** Size and design of roof outlets are critical aspects of building rainwater drainage system. Roof outlets with dome gratings are preferred at all locations except where pedestrian movement is expected in which cases outlets with flat gratings have to be used. The net area of openings of gratings shall not be less than 200% and 150% of the area of the outlet pipe for flat and dome gratings respectively.



*Figure 6.2.5: Roof Outlets (Dome, Flat and Side)*

**6.2.6** Once the rainfall intensity and area to be drained are established, sizing of roof outlets, pipes, gutters, etc. will be a relatively simple exercise. Plumbing Codes such as UIPC-I provide tables for ready reference indicating data on selection of vertical and horizontal pipe sizes at various rainfall intensities. While calculating roof area to be drained, it is important to note that contributory surfaces such as adjoining walls etc shall be added to the horizontal surfaces in prescribed percentages as provided in the plumbing codes.

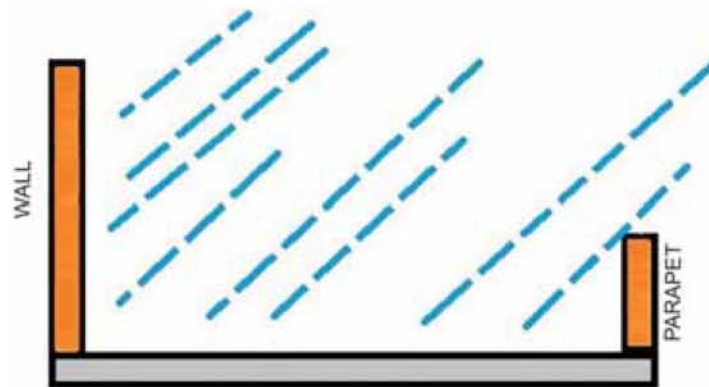

*Figure 6.2.6: Tributary Catchment Areas*

**6.2.7** Horizontal drain pipes will have lesser carrying capacity compared to vertical drain pipes of the same size. Any change in diameters shall be implemented on the vertical pipe as shown on fig 6.2.4. Similarly, horizontal/angular roof outlets will have lesser capacities compared to vertical roof outlets. Therefore, the profile/routing of the pipe and the type of roof outlet used should be taken into account while determining the pipe sizes. Capacities of roof outlets expressed in roof area catered to are also often provided in manufacturer's recommendation.

**6.2.8** Secondary roof outlets installed minimum 50 mm above the roof surfaces are also provided as an additional precaution to cater to excessive rainfalls or as standby arrangement in the event the primary outlets are not functional.

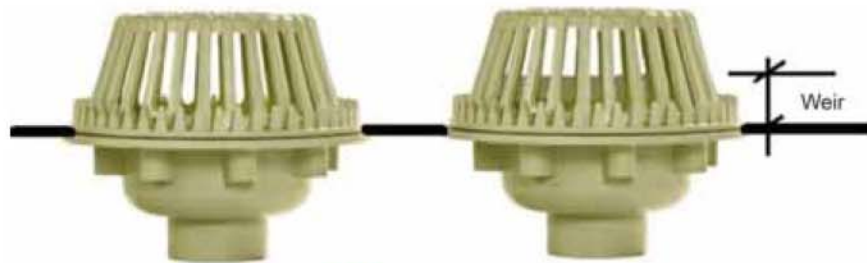
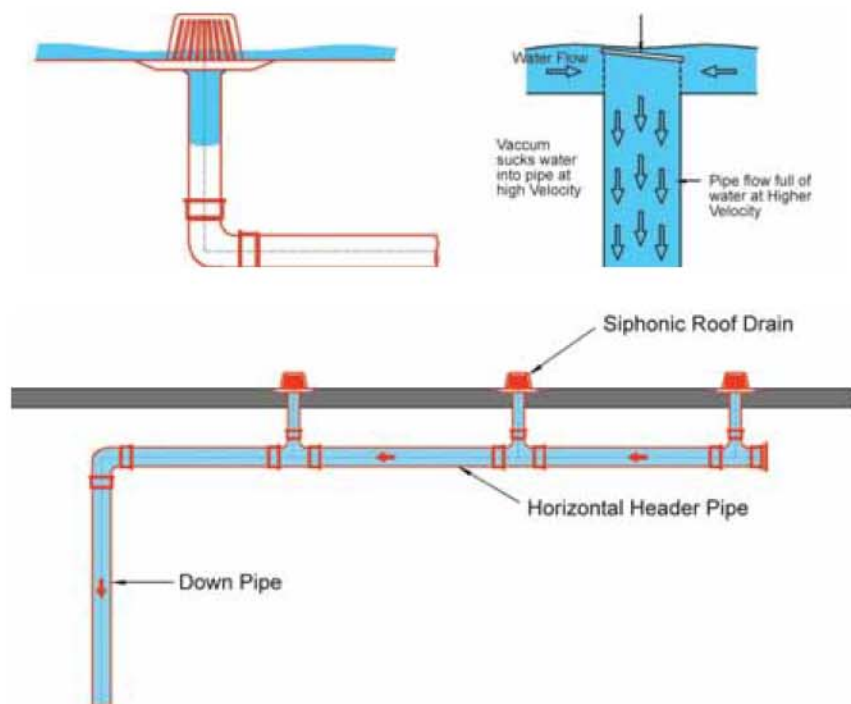

**Figure 6.2.8:** Secondary Roof Outlets

6.2.9 External rainwater (storm water) drainage systems shall include provisions of appurtenances as described earlier for sanitary drainage system except that traps with water seal, ventilating pipes, air-tight covers, etc. are not required.

### 6.3 Siphonic Rainwater System

6.3.1 Siphonic Rainwater System is an engineered installation, generally used for special situations such as roofs with large spans for structures like hangars, airport terminals, stadiums, and industrial sheds, etc. where the number of downpipes has to be limited. As the Siphonic systems are designed for full flow of pipes, economy in pipe sizes can be achieved. The roof outlets used in these installations are also different from the conventional ones. Siphonic Rainwater System shall be designed by specialized manufacturers with the required technical knowhow. The illustrations hereunder provide general information on the system.



**Figure 6.3.1:** Siphonic Rain Water System

## 6.4 Collection and Storage

6.4.1 As described in 6.2 above, rainwater from built roofs can be collected and reused with adequate treatment as a measure of water conservation. In such cases, provision shall be made for 'first flush' to drain away water from the earlier rains which may contain suspended particles, bird droppings, leaves, etc.

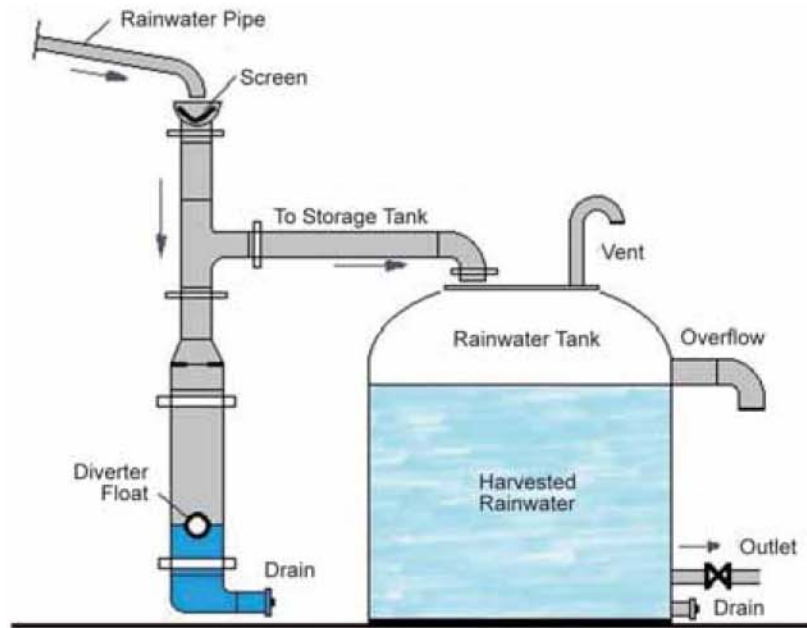

Figure 6.4.1a: Rain Water Collection System

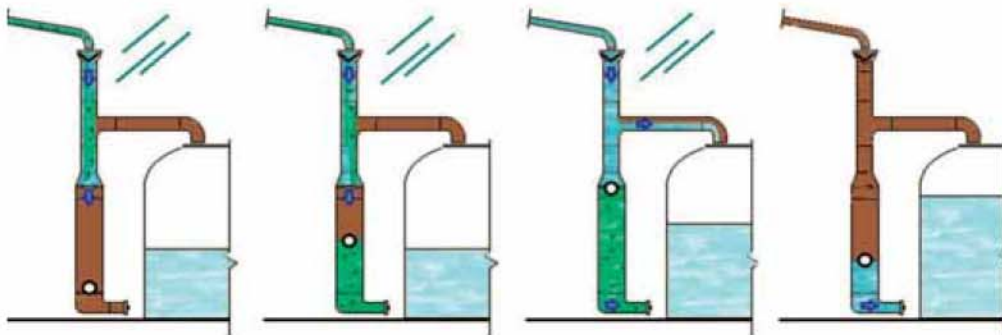

Figure 6.4.1b: Working of First Flush

6.4.2 Plumbing codes stipulate usage of harvested rain water for non-potable applications such as flushing of toilets, landscape irrigation and make-up water for air conditioning systems. However, if appropriate provisions are made to ensure prescribed quality of water, rainwater can be used for potable applications also. These systems are relatively easy to implement in smaller buildings such as individual homes rather than large complexes.

6.4.3 Storage capacities are to be calculated considering the catchment area and rainfall intensity included in the design of the system. In several parts of the country a storage equivalent to 30 minutes rainfall at 100 mm/hr is considered appropriate. While constructing storage tanks, all provisions and precautions as described earlier in this publication for potable water tanks shall be adhered to.

## 6.5 Recharge and Disposal Systems

6.5.1 Statutory regulations on rain water harvesting provide for collection and reuse as described under 6.4 and/or recharge of the underground water aquifer to improve the water table. Several methods are prevalent for recharging systems depending on the ground strata, water table, etc. Appropriate system(s) for specific projects shall be implemented in consultation with plumbing engineers.

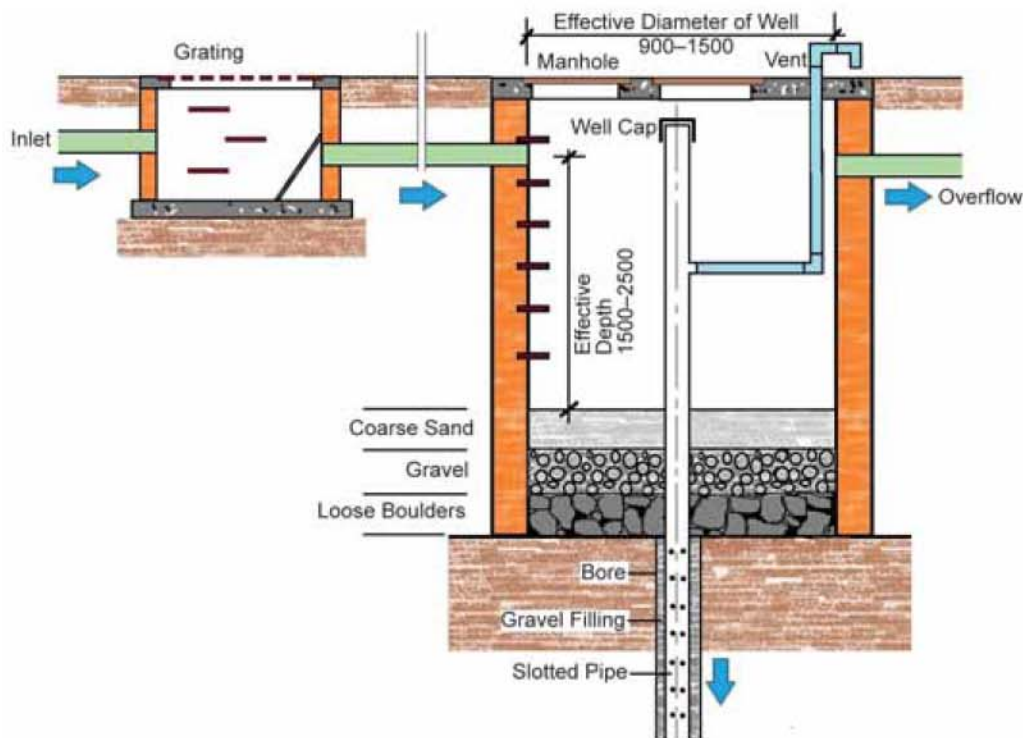

**Figure 6.5.1:** Rainwater Recharge Pit

6.5.2 At locations with high ground-water table or excessive rainfall, provision shall also be made for disposal of rain water to adjacent water bodies, public storm water drains, etc.

# Retrofitting of Plumbing Systems

## 7.1 General

**7.1.1** Constant advancement of technology in the plumbing industry necessitates that installations carried out years ago be reviewed and essential modifications be implemented for up-gradation and compliance with latest standards. This is of particular relevance taking into account the current focus on water conservation and other green plumbing measures. This chapter attempts to briefly review the salient points related to retrofitting of plumbing systems.

## 7.2 Sanitary Fixtures and Appliances

**7.2.1** Relative easing of import restrictions and opening of the Indian economy has resulted in availability of plumbing fixtures and faucets of global standards from reputed manufacturers. As water conservation is mandated in most nations with advanced plumbing standards, a vast majority of these imported products comply with the current standards. A flushing cistern for water closets used to discharge 12.5 ltr, 9 ltr, 6 ltr per flush in the not too distant past, whereas the current focus is to reduce these consumptions to 4.5 ltr or even lesser using dual flushing mechanism. Similarly, showers and other faucets are now available with modern technology resulting in vastly reduced flow rates.

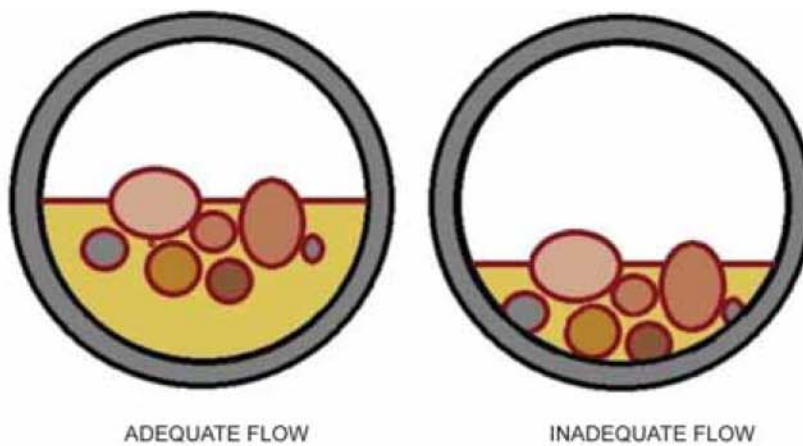

*Figure 7.2.1: Dual Flushing Cistern*



7.2.2 While replacing the sanitary fixtures and faucets in buildings with modern products as described above, care shall be taken to ensure that the water distribution and drainage systems are also appropriately modified.

7.2.3 A common problem addressed by plumbing engineers across the globe today is what is termed as 'dry drain phenomenon'. Gravity drainage systems depend on liquids as medium to carry the solids. Reduced water flow from water efficient fixtures, further aggravated by waterless fixtures, result in negating 'self-cleansing velocities' causing blockage of drains. While attempting to comply with the much needed requirement of water conservation, caution shall be exercised to alleviate possible dangers of blocked drains and unsafe sanitary conditions.

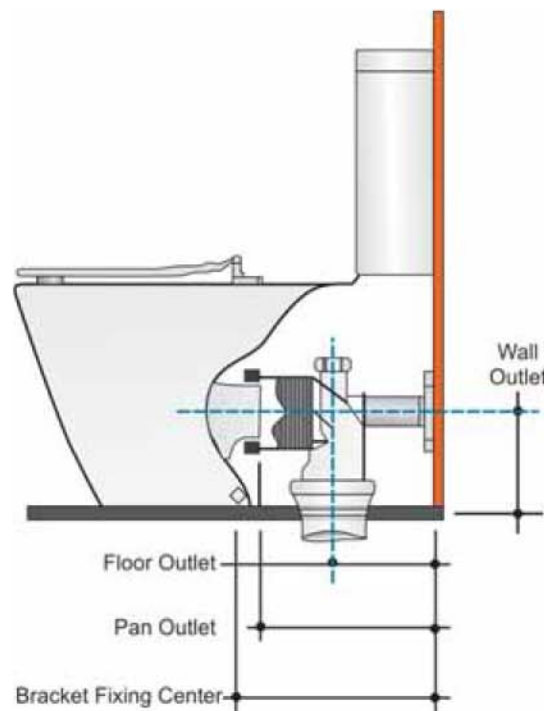

*Figure 7.2.3: Dry Drains*

7.2.4 Some of the measures to be looked into while retrofitting of sanitary fixtures and faucets are as follows:

- Various models of water closets, flushing appliances, bidets, urinals, bath tubs etc. from different manufacturers will have varying dimensions of water supply inlets and drainage outlets. The new fixtures and faucets to be introduced shall, as far as possible, cause minimum requirement of modifications to existing pipe work and related civil works.
- Many of the modern fixtures and faucets may require higher working pressures. When installed with existing water distribution systems, introduction of booster pumps may have to be considered.
- The quality of existing water distribution pipe work shall be examined to ensure that they can withstand the possible increased working pressures of new fixtures.
- Rated working pressures of water heating appliances such as electric, gas, solar heaters, etc. shall be verified to ensure that they withstand the higher water pressure.
- Current mandatory standards stipulate usage of alternative source of water (non-potable) for flushing of water closets and urinals, calling for dual water supply piping systems. Additional pipe work may have to be installed to comply with this requirement. Special care should be taken to avoid cross connection between potable and non-potable water systems

- While replacing conventional shower heads with low flow fixtures, care shall be taken to verify the quality of the fittings since sub standard fittings may cause severe accidents from scalding/thermal shocks. Ideally the mixers used shall be of temperature and pressure compensating type.
- When bath tubs replace showers, the water supply pipe work may require modification as the bath tub faucets may have higher flow rates than the shower mixers. Flow restrictors are not provided on bath spouts even in installations focusing on water conservation measures because it's function is to fill a fixed capacity in a short time. Storage capacity of existing water heating systems may have to be changed to meet the enhanced requirement.



**Figure 7.2.4a:** Critical Installation Data

### 7.3 Augmentation of Water Storage

7.3.1 Several statutory requirements currently being implemented may not have been prevalent when an existing installation was carried out. Usage of alternative water sources now regularly implemented will call for additional independent compartments for storage of different categories of water. The retrofitting exercise also provides an opportunity to inspect and repair/replace damaged storage systems.

### 7.4 Improvements of Piping Systems

7.4.1 Availability of better type and quality piping systems and appurtenances can be made use of for repairs and replacement of existing piping systems where site conditions and budgets permit. For example, until recently the most commonly

used material for potable water distribution systems was galvanized steel tube and fittings. These are gradually being phased out and replaced with modern plastic and composite piping systems. Similarly, the most commonly used piping material for external gravity drainage systems was stoneware despite its major limitations. Plastic piping systems are currently available as a substitute. These are also being used to replace drainage within buildings with asbestos pipes (with major limitations and health concerns).

7.4.2 Modern appurtenances such as water hammer arrestors, pressure reducing valves, safety valves, expansion vessels and automatic air vents for water distribution systems and back water valves, air admittance valves, positive air pressure attenuators etc. for drainage systems are currently available. Introduction of these products, where applicable, to existing installations will enhance performance of the systems.



*Figure 7.4.2: A Modern Plumbing Fixture*

# Materials/Equipment

## 8.1 Sanitary Fixtures and Fittings

Primary consideration in selection of materials for sanitary fixtures is that they should be impervious and easy to clean and maintain in hygienic conditions. Therefore, the choices of materials for water closets, wash basins, urinals, bidets and sinks are usually limited to vitreous china, stainless steel, glass and in rare cases fireclay. Additionally, shower trays and bath tubs are also made in acrylic, fiber reinforced plastic, cast iron/pressed steel enameled and in approved synthetic materials. Flushing cisterns, seats and covers for European closets are manufactured in polypropylene, acrylic and composite wood.

Fittings described here include faucets, showers, flush valves and wash room accessories such as towel rails, robe hooks, toilet paper holders etc. Faucets, showers and flush valves are generally made of brass with chrome plated finish. Wash room accessories are manufactured in brass with chrome finish and also in stainless steel. These products are also manufactured in various engineered plastics.

## 8.2 Water Supply

Materials described here are for pipes, fittings, valves, appurtenances, storage cisterns (tanks), etc.

### Cold Water Distribution:

- *Plastic Pipes:*  
Unplasticised poly vinyl chloride (uPVC), chlorinated polyvinyl chloride (CPVC), poly propylene random (PPR), composite, polybutane(PB), cross linked polyethylene (PEX).
- *Metallic Pipes:*  
Galvanised steel, stainless steel, copper.
- *Fittings:*  
As per manufacturers' recommendation.

### Hot Water Distribution:

- *Plastic Pipes:*  
Chlorinated polyvinyl chloride (CPVC), poly propylene random (PPR), composite, polybutane(PB), cross linked polyethylene (PEX).

- *Metallic Pipes:*  
Galvanised steel, stainless steel, copper.
- *Fittings:*  
As per manufacturers' recommendation.
- **Valves and Appurtenances:**
- Brass, gun metal, stainless steel, cast iron, ductile iron, glass filled nylon and several other materials as described above for pipes and fittings.

#### **Storage Cisterns (Tanks):**

- Reinforced cement concrete, masonry, mild steel, stainless steel, polyethylene, sheet molded compound, glass reinforced plastic, fiber glass reinforced plastic.  
Materials to be used shall be selected based on their application (hot water, cold water) and pressure rating.

### **8.3 Drainage**

Materials described here are for pipes, fittings, traps, interceptors, gratings and in-situ structures such as manholes, inspection chambers, gully traps, catch basins, valve chambers, channels/gutters, silt traps, septic tanks and soak pits, etc.

- *Pipes and fittings:*  
Stoneware, vitrified clay, RCC, uPVC, GRP, cast iron, HDPE, PP.
- *Main drain traps:*  
Stoneware, uPVC, cast iron, HDPE, PP.
- *Fixture traps:*  
Brass, copper, ABS, uPVC, PP.
- *Gratings:*  
Brass, stainless steel, plastics.
- *Gratings for external installations:*  
Cast Iron, ductile iron, SFRC, fabricated mild steel, stainless steel.
- *In-situ structures:*  
RCC, masonry.

### **8.4 Pumping Equipment**

- *Pump bodies:*  
Cast iron, stainless steel and plastic for smaller units.
- *Internal components:*  
Bronze, stainless steel, carbon steel, cast iron, engineered plastics.

# Washrooms for Differently Abled

## 9.1 General

It is mandatory that the built environment (whether they are residential, commercial or public spaces) incorporate elements to make them user friendly for the differently abled and for the elderly. Consequently, permits for new buildings are issued only if features such as ramps for wheelchair users are provided. Several publications currently available provide the required data for designing of washrooms for the differently abled. One such publication is from the Ministry of Urban Affairs (India) which, through the Central Public Works Department has issued an exhaustive document called 'Guidelines and Space Standards for Barrier Free Built Environment For Disabled And Elderly Persons'. Design of washrooms is dealt with, in this publication.

The basic principle in designing such a washroom is to provide a barrier free space facilitating wheelchair access (with or without assistance).

## 9.2 Design Criteria of Washrooms

### 9.2.1 Overall Dimensions

The dimensions of a washroom will depend on the number of fixtures/amenities provided. Fig 9.2.1 shows a typical washroom with a water closet, shower and washbasin. Considering the space required for ease of manoeuvring the wheelchair, the recommended size is minimum 2200 × 1750 mm. Adding or reducing the number of fixtures will obviously alter the space requirements. Suitable modifications can be effected to meet individual needs.

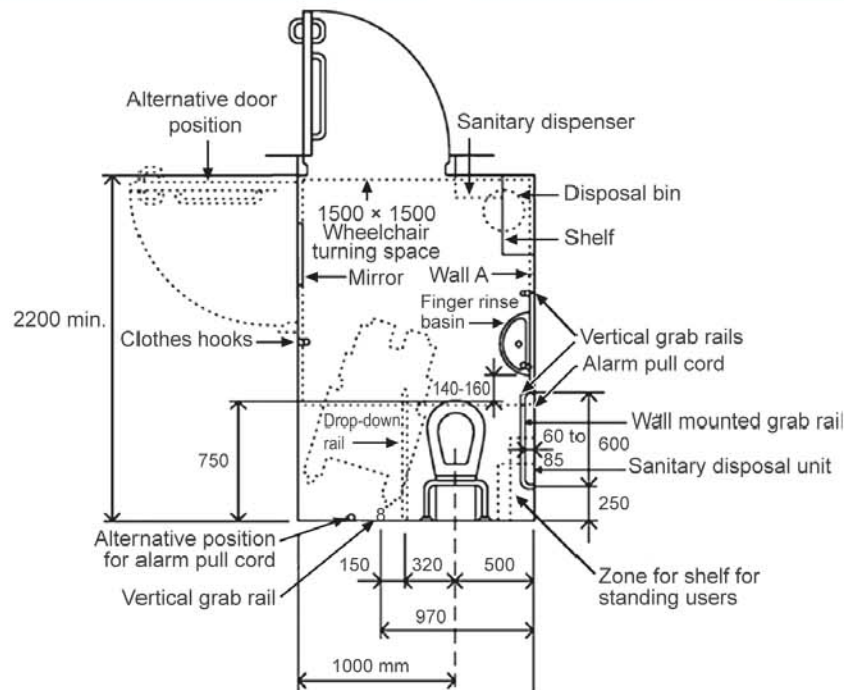

**Figure 9.2.1:** Washroom Dimensions

### 9.2.2 Doors

- Minimum width shall be 900 mm.
- They shall be sliding or opening outwards.
- Handles shall be push or lever type to ensure ease of operation.
- Doors shall be openable from outside during any emergency.

### 9.2.3 Floors

- Shall be non skid.
- Shall not have any sudden dips or any perceptible level difference.
- If thresholds are provided, they shall not exceed 13 mm and shall have beveled edges.

### 9.2.4 Water Closet

- The seat, when opened, shall be 500 mm above the finished floor.
- Flush controls shall be situated between 600 mm to 1050 mm above the finished floor level. It shall be easily operable with one hand if manual or shall be automatic.
- If dedicated cubicles are provided, they shall be of a minimum size of 1500 mm × 1500 mm.

### 9.2.5 Wash Basins

- The rim shall not be higher than 750 mm above the finished floor level.
- Alternatively height adjustable units can be provided.
- The faucets shall be automatic or lever operated.
- Hot and cold water mixers shall have thermostatic controls to prevent scalding.

### 9.2.6 Urinals

- In public toilets, urinals shall have a clear space of not less than 800 mm × 1500 mm.
- The rim of the urinal shall not be higher than 400 mm above the finished floor level.

### 9.2.7 Showers

- Shower compartments shall have minimum dimension of 900 mm × 1500 mm.
- The door shall preferably be sliding.
- Shower cubicles shall be provided with seats fixed to the walls. They shall preferably be foldable.
- Showers shall be of hand held type with a hose of at least 1500 mm length.

### 9.2.8 Bath tubs

- Height shall not exceed 380 mm.
- A clear space of 800 mm shall be provided in front, along the length of the bath tub.
- Faucets shall be within a height of 450 mm above the rim. Thermostatic mixers are recommended.
- Showers shall be of hand held type with a hose of at least 1500 mm length.

### 9.2.9 Grab bars

An important element of a washroom for the differently abled is the provision of grab bars. They shall be firmly fixed and capable of withstanding a static load of 150 kg. The diameter of the grab rail shall be 35–50 mm with a non-slip finish. They shall have a clear gap of 30 mm from the wall.

Grab rails of appropriate design shall be provided for wash basins, water closets, urinals, bath tubs and showers. Foldable (lockable in place) rails are preferred to facilitate ease of transfer of the user from and to the wheel chair.

All products used in washrooms for differently abled shall comply with prescribed standards and procured from specialist manufacturers.



**Figure 9.2a:** Fixture Layout





Figure 9.2b: Fixture Layout

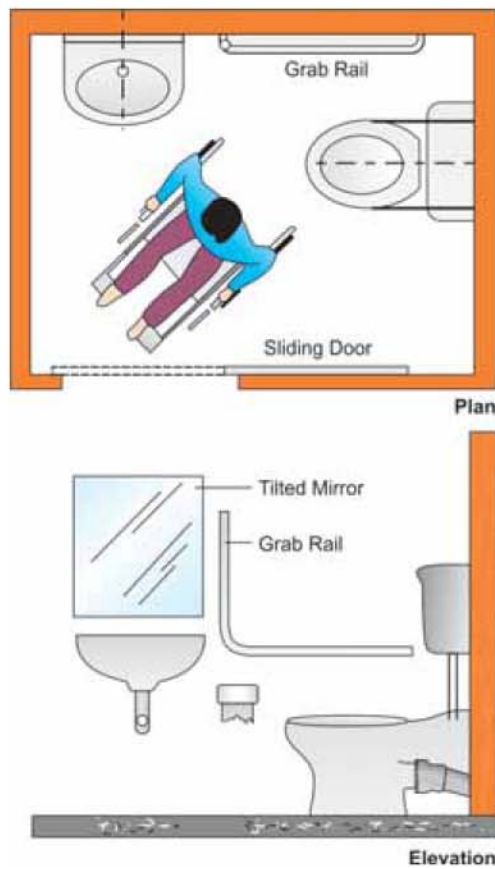

Figure 9.2c: Fixture Layout



Figure 9.2d: Mounting Height of EWC



Figure 9.2e: Shower Arrangement

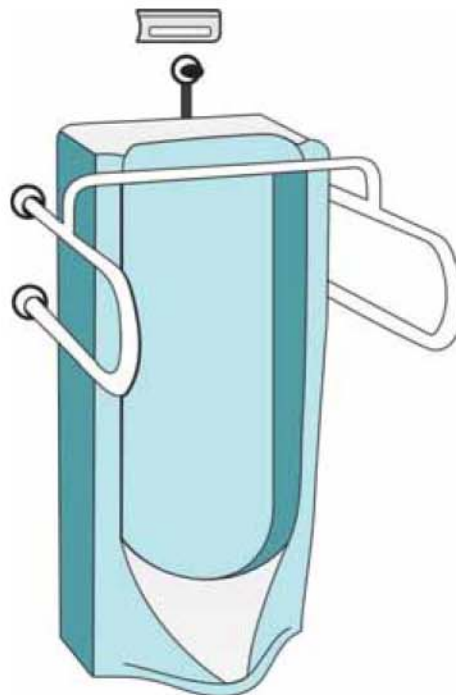

Figure 9.2f: Urinal



# Water Conservation

## 10.1 General

**10.1.1** As water is a finite resource and as consumption keeps rising due to increase in population and modern life style, conservation measures are being adopted across the globe. Largest consumption of water is for agriculture, followed by industries. Water consumption for domestic applications within buildings constitutes approximately 10% of the total water consumed.

## 10.2 Water Conservation Measures

Water conservation measures described here are limited only to the domestic water used for human consumption and include use of the following:

- Low flow faucets and showers.
- Dual flush cisterns for water closets consuming no more than average 4 ltr per flush (flush volume of 4 ltrs for dual flush cisterns are calculated as an average of two 3 ltr flush and one 6 ltr flush).
- Sensor operated (electronic) flushing devices for urinals with flush volume of no more than 1 ltr.
- Metered faucets (electronic/mechanical) for wash basins in public wash rooms.
- Pressure and flow regulators in faucets and showers.
- Cloth washers and dish washers consuming reduced volume as per Water Efficient Products-India (WEP-I)
- Water meter for monitoring consumption at different zones.
- Alternative water sources (recycled/reclaimed, on site water sources, harvested rain water, etc.) for non- potable applications such as flushing, landscape irrigation and HVAC makeup water.

Water conservation measures shall also include preservation and protection of existing sources by ensuring that they are not polluted by discharge of untreated waste water, contaminated surface water, etc.

In order to ensure conservation of water by use of fixtures and fittings as mentioned above, third party certified products are recommended. Testing and certification programs are currently implemented in India based on UIPC-I and WEP-I -publications by IPA and IAPMO.

Water conservation measures described above are likely to save up to 30% on the cost of water consumed and indirectly the energy consumed.



## Operation and Maintenance

Like every other installation, plumbing systems require periodic inspection, testing and maintenance. Attention to the following will facilitate a trouble-free plumbing system.

- Ensure that the water storage tanks are always kept clean, free of foreign matter and entry of surface water.
- Check water quality periodically by getting samples analyzed by approved laboratories.
- Ensure rotation and priming of pumps to avoid dry running and resultant damage to motors.
- Inspect for gland leakages of pumps and valves and rectify, if any.
- Remove, clean and reinstall strainer element if 'Y' /pot strainers are installed at pump suction.
- Inspect foot valves for leakages and rectify, if any.
- Inspect the system pressure and ensure that it conforms to design parameters.
- Check operation of isolating valves, non-return valves, float valves, pressure regulators, pressure gauges, automatic air vents, etc.
- Check operation and correctness of water level controllers and sensors.
- Inspect pipe supporting systems, clamps, etc.
- Remove, clean and reinstall aerators and flow controllers on faucets and showers.
- Periodically service domestic water purifiers and replace filter elements as per manufacturer's recommendation.
- Inspect thermostats, temperature gauges and safety valves of water heaters.
- Inspect and clean faucets and repair any leaking faucets.
- Inspect and clean (with approved cleaning agents) sanitary fixtures regularly.
- Inspect the sealants used at tile joints, especially at shower cubicles/vanity tops/wet areas and replace where necessary.
- Protect faucets, showers, etc. from corrosive cleaning agents used for cleaning of wash room surfaces.
- Inspect water seals in floor drains, especially after the premises are not used for a while and replenish by pouring water.

- Inspect traps, inspection chambers, manholes, etc. Remove any accumulated solids/foreign matter.
- Remove, clean and reinstall covers of manholes, inspection chambers, gully chambers, valve chambers and water tanks, etc. using automobile grease or similar material.
- Inspect vent cowls on drainage pipes and ensure they are not obstructed.
- Prior to and during monsoon, inspect rain water outlets to ensure that they are not blocked.

## Chapter 12

# Records

Records of installations carried out shall be maintained for future repairs, maintenance or refurbishments.

Deviations from working drawings during construction shall be recorded from time to time and as-built drawings shall be produced and handed over to the end user. As-built drawings shall contain important information such as routing of pipe work, location of isolating valves and other appurtenances, equipment layouts, etc.

In addition to as-built drawings, user manuals, warranty certificates and manufacturers' catalogues of all products installed shall be retained.

On large projects, an 'Operation and Maintenance Manual' shall be presented on commissioning of the installations. An O&M Manual shall contain the following minimum details:

- A brief description of the project
- Broad parameters of installations carried out with system description
- Schedule of as-built drawings
- Schedule of equipment and materials used
- Test and calibration certificates
- Valve identification chart
- List of spare parts
- Warranty certificates
- Lists of routine and preventive maintenance with schedules
- List of manufacturers and contact details





## Suggested Additional Reading

A **GUIDE TO GOOD PLUMBING PRACTICES** contains basic information on plumbing systems. For further reading and additional detailed engineering information, the Indian Plumbing Association (IPA) recommends the following:

- National Building Code of India published by the Bureau of Indian Standards
- Guidelines and Space Standards for Barrier Free Built Environment For Disabled And Elderly Persons issued by Ministry of Urban Development (India)

Publications jointly created by IPA and International Association of Plumbing And Mechanical Officials (IAPMO):

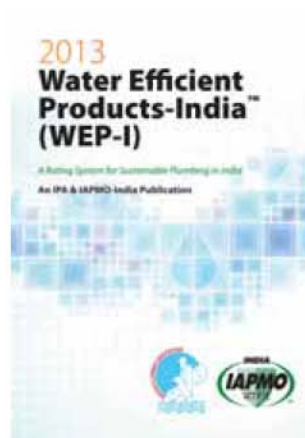
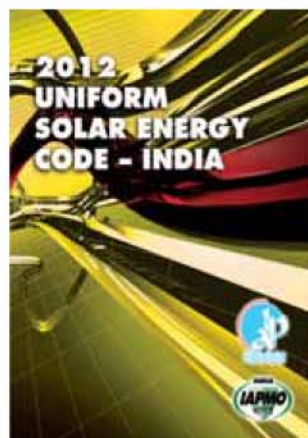
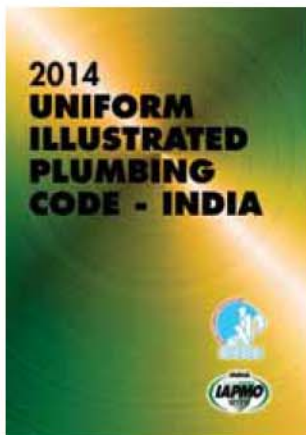



# Acknowledgements

The Indian Plumbing Association gratefully acknowledges the support from the following organisations for publication of first edition of this valuable technical document



Ashirvad Pipes Pvt Ltd  
4-B, Attibele Industrial Area,  
Hosur Road  
Bangalore-562 107,  
Karnataka, India  
Phone: +91 80 2782 0542  
Fax: +91 80 2782 0463  
Email: info@ashirvad.com  
web: www.ashirvad.com



Jain Irrigation Systems Limited  
Jain Plastic Park, P.O.Box: 72  
Jalgaon 425 001(India)  
Tel: +91-257-2258011  
Fax +91-257-2258111  
Email : jisl@jains.com  
web: www.jains.com



Astral Poly Technik Limited  
207/1, Astral House  
B/h Rajpath Club  
Off S.G. Highway,  
Ahmedabad-380059, India  
Ph: +91 79 6621 2000  
Email: info@astralpipes.com  
web: www.astralpipes.com



KITEC Industries (India) Limited  
C-18/11, Jeevan Bima Nagar  
Borivali – West, Mumbai – 400 103  
Ph:+91 22 2985 1144; Fax: +91 22 2894 2549  
Email: kitec.services@gmail.com  
web: www.kitecindia.com; www.kitecindia.in



Lubi Industries LLP  
Near Kalyan Mills, Naroda Road  
Ahmedabad-380025  
Phone: 079-30610100  
Fax: 079-30610300  
Email : mktsales@lubipumps.com  
web: www.lubipumps.com



FLOW HOT, FLOW COLD CONFIDENTLY

Lubrizol Advanced Materials India Pvt Ltd  
6th & 7th Floors, Jaswanti Landmark  
Mehra Industrial Estate, L B S Marg  
Vikhroli-West, Mumbai 400 079  
Ph: +91 22 6602 7800; Fax: +91 22 6602 7888  
Email: flowguard.india@Lubrizol.com  
web: www.lubrizol.com



Prince SWR Systems Pvt Ltd  
Regd Office: Sunshine Plaza,  
1st Floor  
Naigaum Cross Road  
Dadar (E), Mumbai –400 014  
Website: www.princeswr.com  
Ph: +91-22-4030333/44/55  
Telefax : +91-22-40303322  
Email: info@princeswr.com  
web : www.princeswr.com



Geberit Plumbing Technology India Pvt Ltd  
At The Lalith Ashok Bangalore  
Kumara Krupa High Grounds  
Bengaluru-560 001, India  
Ph: +91 80 3925 1101  
Email: sales.in@geberit.com  
web: www.international.geberit.com



Grundfos Pumps India (Pvt) Limited  
118, Rajiv Gandhi Salai  
Thoraipakkam  
Chennai – 600 097, Tamil Nadu  
Phone :044-4596 6800, Fax : 044-4596 6969  
Toll free: 1800 345 4555  
Email: salesindia@grundfos.com  
web: www.grundfos.in



The Supreme Industries Limited  
Unit No. III, Gate No. 47/48,  
AT & PO: Gadegaon, Taluk-Jamner  
Dist. Jalgaon-425 114 (MS)  
Phone: 022 67710000/40430000, 0257 3050541/3050690  
Email: info@supreme.co.in  
web: www.supreme.co.in



Viega GmbH & Co. KG  
H/O: 1005, DLH Park  
Opp. MTNL Building  
S.V. Road, Goregaon West  
Mumbai 400062  
Ph: +91 22 28715160  
Fax: +91 22 28715170  
Email: Shailesh.khamar@viega.in  
web :www.viega.com

# A GUIDE TO GOOD PLUMBING PRACTICES

Is designed to cater to professionals as well as the general public. This ready reckoner will prove to be an ideal reference for students of Engineering, Architecture, Interior Design and related subjects, to those aspiring to be part of the plumbing fraternity and end users of plumbing services.

This publication is an original creation of the Technical Committee of Indian Plumbing Association. Consisting of fifteen chapters, explained in simple language with sketches and illustrations, the publication covers most of the important topics related to plumbing practices.

This guide is a recommended reading for those practicing in the construction industry.

Developed and Published by



## Indian Plumbing Association

416, DLF Prime Towers, F- 79 & 80, Okhla Phase - I, New Delhi 110020

Phone: 011-49863152 – 53, E-mail : [hq@indianplumbing.org](mailto:hq@indianplumbing.org)

[www.indianplumbing.org](http://www.indianplumbing.org)

₹500/-

ISBN: 978-81-239-2889-0



9 788123 928890